



Coimisiún na Scrúduithe Stáit State Examinations Commission

JUNIOR CERTIFICATE EXAMINATION, 2018

SCIENCE – HIGHER LEVEL

MONDAY, 11 JUNE – AFTERNOON, 2.00 to 4.00

INSTRUCTIONS

1. Write your **examination number** in the box provided on this page.
2. Answer **all** questions.
3. Answer the questions in the spaces provided in this booklet. If you require extra space, there is a blank page provided at the back of this booklet.
4. The use of the *Formulae and Tables* booklet approved for use in the State Examinations is permitted. A copy may be obtained from the examination superintendent.

Centre Number

**Examination
Number**

For examiner use only	
Section / Question	Mark
Biology	
Q.1 (52)	
Q.2 (39)	
Q.3 (39)	
Chemistry	
Q.4 (52)	
Q.5 (39)	
Q.6 (39)	
Physics	
Q.7 (52)	
Q.8 (39)	
Q.9 (39)	
Total (Paper)	
Bonus for Irish	
Grand Total (Paper) (390)	
Coursework A (60)	
Coursework B (150)	
Grand Total (600)	

Biology

For
examiner
use only

(1) (2)

Question 1

(52)

(a) The animal kingdom is divided into two main groups, vertebrates and invertebrates.

(i) Name one vertebrate. _____

(ii) What is an invertebrate? _____

(b)(i) Name the blood vessel labelled **X** on the diagram of the human circulatory system.

(ii) Blood is pumped from the heart to another organ through blood vessel **X**.

Name this organ. _____

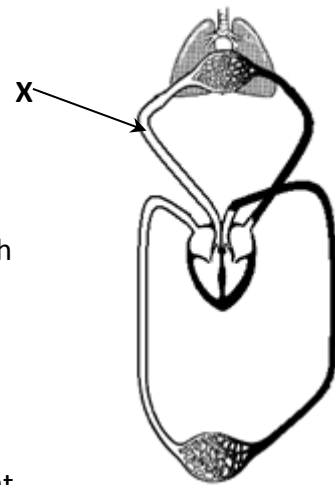

(c) Below is an example of a food chain from a garden habitat.

ROSEBUSH → **GREENFLY** → **LADYBIRD** → **SPIDER**

(i) What word describes the role of the rosebush in this food chain? _____

(ii) Explain what would happen to the size of the spider population in this habitat if all the rosebushes died. _____

(d) Study the diagram of the human digestive system and answer the following questions.

(i) State one function of the stomach.

(ii) Name the organ labelled **Y**.

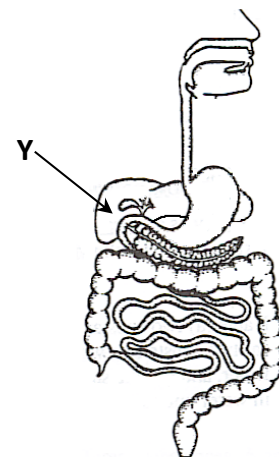

(e) The plant in the diagram is growing towards the sunlight.



(i) Name this growth response.

(ii) Explain why this growth response is of benefit to the plant. _____

(f) An earthworm takes in and uses up a certain gas during respiration.

(i) Name the gas the earthworm uses up during respiration.

(ii) Name a gas the earthworm produces during respiration.



(g)(i) What type of tissue transports water and minerals in a plant?

(ii) Water is lost from which plant organ during transpiration?

(h) A student carried out an experiment to show that starch is produced in a green plant during photosynthesis.

(i) Name a plant process that uses starch. _____

(ii) Explain how the student removed starch from the plant before the start of the experiment. _____

(iii) Name a chemical used by the student to remove chlorophyll from the leaves of the plant. _____

(iv) Name a chemical used by the student to test for the presence of starch in the leaves. _____

For
examiner
use only

(1) (2)

(7 × 6 + 1 × 10)

Question 2

(39)

For
examiner
use only

(1) (2)

(a) A chef accidentally touches a hot flame. As a result, the nerve cells in her skin send a message to a part of her body. A message then travels back to the muscles in her arm, causing her hand to be pulled away. (12)

(i) Name the type of nerve cell that sent the message from the skin.

(ii) Name the part of the chef's body that receives this message.

(iii) Based on this example, explain how the nervous system is important to living organisms. _____

(iv) If the chef had seen the hot flame, name the nerve that would transmit this information from her retina. _____



(b) An athlete was encouraged to eat chicken and pasta before training. (12)

(i) What essential nutrient is abundant in chicken?

(ii) What essential nutrient is abundant in pasta?

(iii) It is also important for the athlete to drink fluids, due to the loss of water during training. State one way in which water is lost from the athlete's body.

(iv) Name the organ in the body which controls the amount of water and salts in the athlete's blood. _____



(c) Cartilage damage is a common type of tissue injury from which athletes suffer. (15)

(i) Explain the underlined term. _____

(ii) Cartilage is found in the body at various joints, such as the one shown.

Name the type of joint shown.

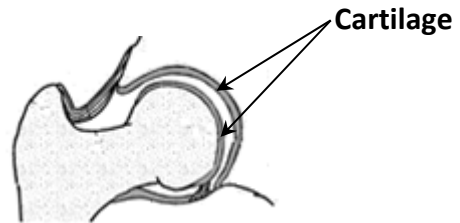

(iii) Note the joints that are circled on the diagram of the human skeleton.

Name one other location in the body where this type of joint is found. _____

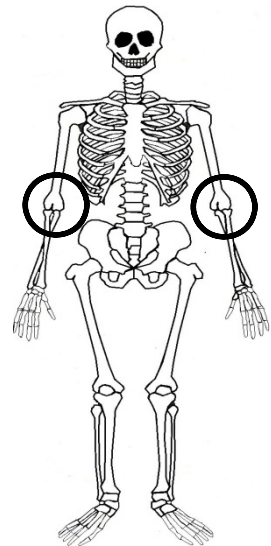

(iv) Name the structures that connect bone to bone in a joint.

Name the structures that connect muscle to bone in a joint.

For
examiner
use only

(1) (2)

Question 3

(39)

For
examiner
use only

(a) The results of a student's habitat study were displayed on a bar chart. (18)

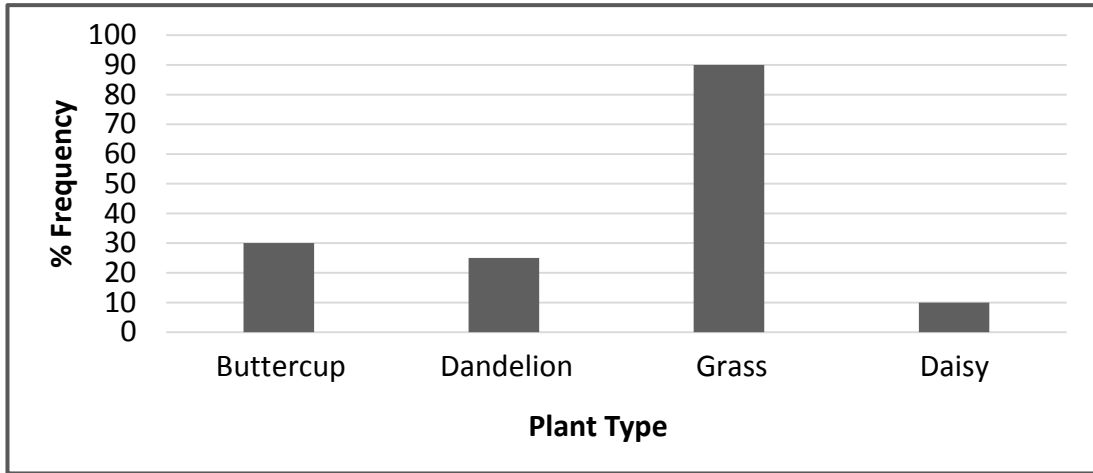

- (i) Name a piece of apparatus which could have been used to measure plant frequency. _____
- (ii) What could the student have used to identify the plants? _____
- (iii) The student noticed that the dandelions had deeper roots than the grass. Name one resource for which the roots of dandelions and grass compete. _____
- (iv) The buttercup, dandelion and daisy have flowers that use insects for pollen transfer. Name the part of the flower that produces pollen. _____
Name the method of pollen transfer used by grass. _____
- (v) Describe an example of how plants and animals can show interdependence. _____

(b) A doctor takes a patient's pulse by listening directly to the heartbeat using a stethoscope. (6)



- (i) Describe another method of taking a pulse. _____

- (ii) What is the average pulse rate per minute for an adult at rest? _____

(1) (2)

(c) A group of students were given an unknown sample of food. They placed equal volumes of the sample into three test tubes and carried out various food tests as shown in the diagrams. (15)

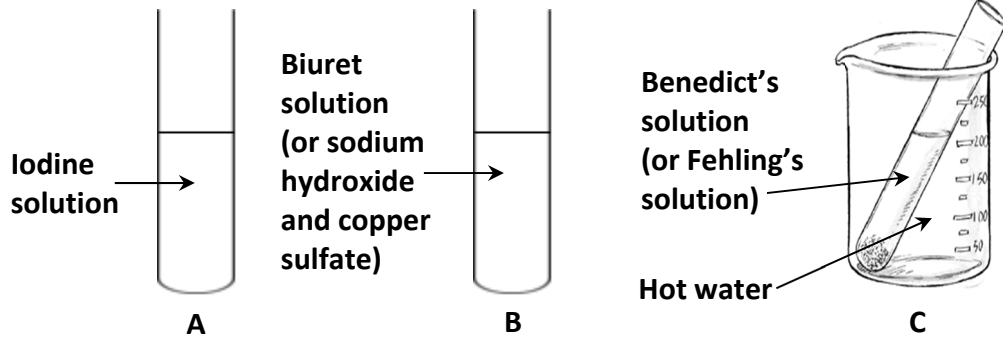

The results were recorded in the table as shown.

RESULTS	
Test tube	Final colour
A	Red-brown
B	Purple
C	Blue

- (i) Based on the findings, which food type did the sample contain? _____
- (ii) Which test tube contained this food type? _____
- (iii) Why was a hot water bath used for test tube C?

(iv) Describe how the students could carry out a control experiment for this investigation. A labelled diagram may help your answer.

Labelled diagram

(v) Describe how to test a food sample for the presence of fat.

For
examiner
use only

(1) | (2)

Chemistry

For
examiner
use only

(1) (2)

Question 4

(52)

- (a) Acid rain is rainfall that is made acidic by pollution.
It can cause environmental harm to forests and lakes.



- (i) Name a gas that dissolves in the rainwater to form this acid rain. _____
- (ii) What activity produces this gas? _____
- _____

- (b) Steel is an alloy and is the main structural material for bridges and buildings.
It is important to prevent the rusting of steel.

- (i) How can the rusting of steel be prevented? _____
- (ii) Name a metal element used in the manufacture of steel. _____

- (c) The world's oceans have become littered with plastic debris and rubbish. Non-biodegradable plastic can spend many years floating in our seas.



- (i) Explain the underlined term.

- (ii) From which raw material are most plastics made? _____

- (d) Substances can be classified as elements, mixtures or compounds.

- (i) What is an element?

- (ii) Describe one difference between a mixture and a compound.

- (e) Liquids have a definite volume and are difficult to compress.
(i) Name a piece of equipment that can be used to measure the volume of a liquid.

- (ii) State one other property of a liquid. _____

- (f) A student carried out an experiment to investigate the solubility of copper sulfate in water.

- (i) Describe the effect of increasing the temperature on the solubility of copper sulfate. _____

- (ii) To prepare crystals, a solution needs to be saturated.

Describe how to make a solution saturated.



- (g) A student set up an experiment to show that there is water vapour in air.

- (i) Name a chemical that can be used to test for water.

- (ii) What colour is this chemical before water is added? _____

- (h) The diagram shows the pH of a number of substances on the pH scale.

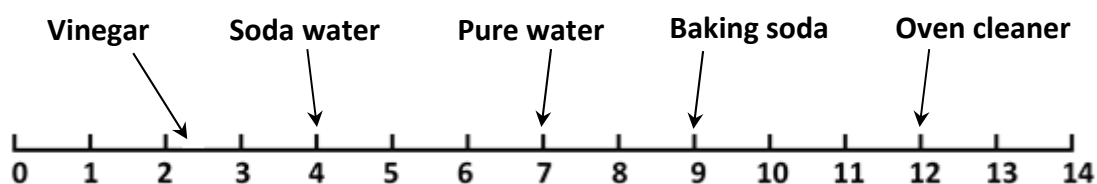

- (i) Choose a substance from the diagram that is:

Acidic _____

Basic _____

Neutral _____

- (ii) State how a student could measure the pH of the substances above.

(7 × 6 + 1 × 10)

Question 5

(39)

For
examiner
use only

(a) The diagram shows the electrolysis of water.
One of the gases produced is hydrogen.

(15)

(i) Is hydrogen produced in test tube **A** or in test tube **B**? _____

(ii) Water contains the elements hydrogen and oxygen only. Name another compound that also contains the elements hydrogen and oxygen only. _____

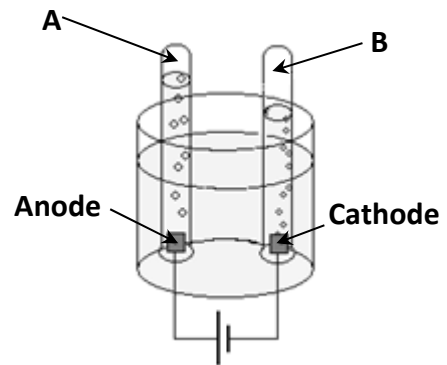

(iii) Describe, with the aid of a labelled diagram, a method (other than electrolysis) that can be used to produce hydrogen gas in the laboratory.

Labelled diagram

(iv) Describe the test for hydrogen gas.

(1) (2)

(b) Students were given a mixture of sand and salt and they were asked to separate the mixture in the laboratory. (9)

(i) First the mixture was added to hot water. What happens to the salt at this stage?

(ii) The next stage of the experiment is to remove the sand from the mixture.

What separation technique can be used to achieve this?

(iii) The final stage of the experiment is to get the salt on its own.

What separation technique can be used to achieve this?

(c) The diagram shows the arrangement of the apparatus used for the preparation of carbon dioxide gas in the laboratory. (15)

(i) Name the solution labelled **A**.

(ii) What is the chemical name for marble chips?

(iii) What property of carbon dioxide causes it to settle to the bottom of the gas jar?

(iv) Write down the balanced chemical equation for the reaction of carbon dioxide with limewater.

Chemical equation

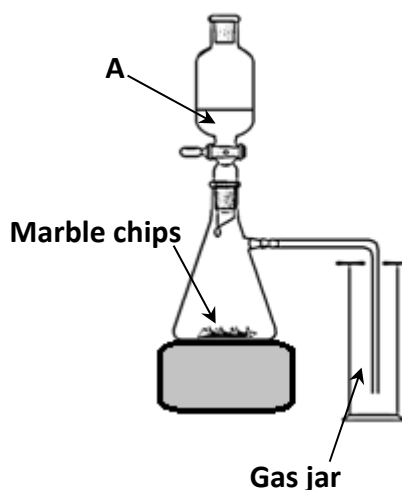

Question 6

(39)

For
examiner
use only

- (a) A student collected water samples from a tap (A), a well (B), rainwater (C) and bottled water (D).

She added a sample of each type of water into a separate test tube.

(15)

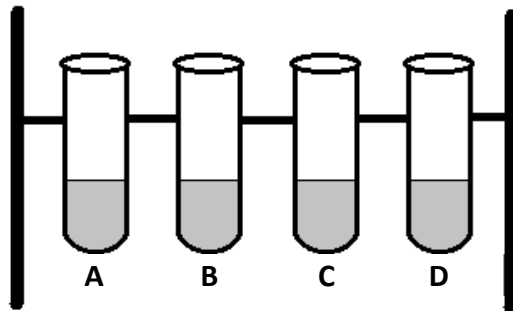

- (i) She then carried out an investigation to test each of the samples for hardness. Describe how this test was carried out.

How did the student know which of the samples was the hardest?

- (ii) Hard water can cause limescale to build up on heating elements, as in the photograph.



However, there are also advantages to hard water.

State one advantage. _____

- (iii) Describe how hardness can be removed from water.

(1) (2)

(b) An atom of sodium has an atomic number of 11 and a mass number of 23. (24)

(i) How many protons does this atom contain? _____

(ii) How many neutrons does this atom contain? _____

(iii) Complete the diagram below, drawing all the electrons on the Bohr structure for this sodium atom. The two electrons on the first shell are already drawn for you.

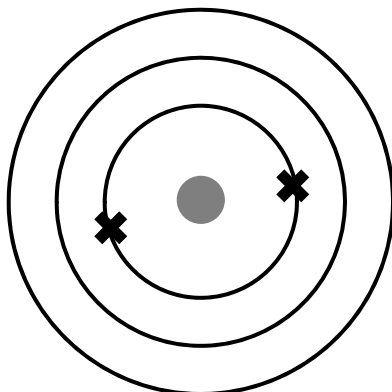

(iv) Name the Group of the Periodic Table to which sodium belongs.

(v) What type of bond does sodium form with chlorine?

(vi) Why is sodium usually stored in a jar of oil, as shown in the photograph?



(vii) When sodium reacts with water, two products are formed. Name these two products.

For
examiner
use only

(1) (2)

Physics

For
examiner
use only

(1) (2)

Question 7

(52)

- (a) The diagram shows a child using a periscope to see over a high wall.

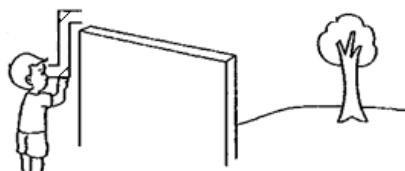

Explain, with the aid of a labelled diagram, how a periscope works.

Labelled diagram

- (b) Wind energy is an example of a renewable source of energy.
Name two other renewable energy sources.



- (c) The relationship between voltage, current and resistance in an electrical circuit is named after the physicist Georg Ohm.

Use Ohm's law to calculate the current in the circuit shown.

Calculation

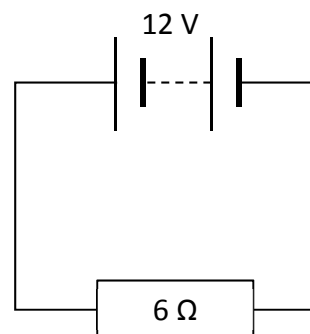

- (d) Copper wire is said to be a good conductor.
Name two physical quantities which this wire conducts.



(e) The mass and volume of a cork are needed to calculate its density.

(i) Name a piece of equipment used to find the mass of the cork.

(ii) The volume of the cork can be found by submerging it in water and measuring the volume of water it displaces.

Explain how you would submerge the cork in water.



(1) (2)

(f) A motorbike accelerates from 12 m s^{-1} to 36 m s^{-1} in 3 seconds.

Calculate the acceleration of the motorbike.

Calculation



(g) The Environmental Protection Agency Act of 1992 defines environmental pollution to include noise pollution.

(i) Why is it dangerous for people to be exposed to very loud sounds?

(ii) Why would noise pollution not be heard in space? _____

(h) The diagrams show bulbs connected in series and in parallel across a battery.

(i) In which circuit, **X** or **Y**, are the bulbs connected in series? _____

(ii) Name device **A**.

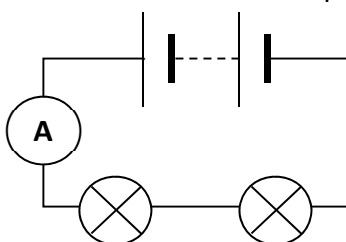

Circuit X

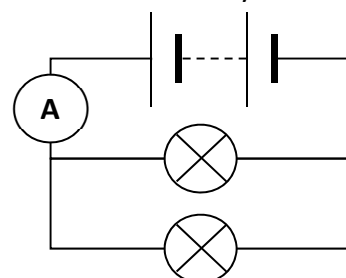

Circuit Y

(iii) Tick (✓) the correct statements for each circuit, **X** or **Y**.

Statement	Circuit X	Circuit Y
The bulbs are brighter.		
If one bulb is unscrewed, no bulb will light.		

(7 × 6 + 1 × 10)

Question 8

(39)

For
examiner
use only

(a) The diagram below shows a ray of light entering a glass block. (12)

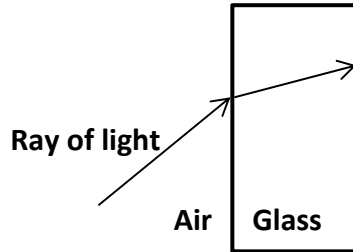

- (i) On the diagram above, complete the path of the ray of light.
- (ii) What word is used to describe the changing of direction of the ray of light as it travels from air into glass? _____
- (iii) Complete the diagram below by drawing the correct lens, which would cause the light rays to focus at a point, as shown.



- (iv) Name one everyday example of an object that uses a lens.

- (b) There are many common forms of energy which can be converted from one form to another in a mobile phone. (9)
 - (i) State the standard unit of energy. _____
 - (ii) When the battery of a mobile phone is being charged, electrical energy is converted to which other form of energy? _____
 - (iii) When a mobile phone is used to listen to music, the energy in the battery is then converted to which other form of energy? _____

(c) Heat is a form of energy whereas temperature is a measure of the hotness of an object. (18)

(i) Name an instrument used to measure temperature and name a unit of temperature.

Instrument _____

Unit of temperature _____

(ii) A student made a toy windmill from thin card and placed it over the flame of a candle. After a while, the windmill began to rotate.



Explain this phenomenon.

(iii) A vacuum flask can be used to keep substances hot or cold. It has a vacuum between two silvered surfaces.

Explain how a flask like this works.

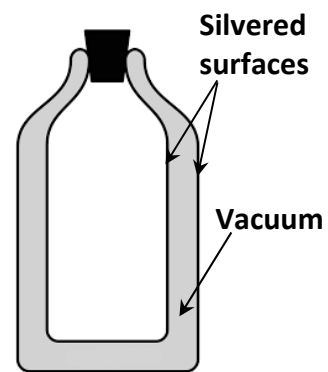

(iv) State one example of insulation that can be used in a house to prevent the loss of heat energy.

For
examiner
use only

(1) (2)

Question 9

(39)

For
examiner
use only

- (a) The table below shows the distances travelled by two athletes, Orla and Molly, during a 100 metre race. (24)

Distance (m)	20.0	40.0	60.0	80.0	100.0
Orla's time (s)	4.0	8.0	12.0	16.0	20.0
Molly's time (s)	4.0	8.0	11.2	14.4	17.6

- (i) Draw graphs in the grid below showing distance versus time for Orla and for Molly.

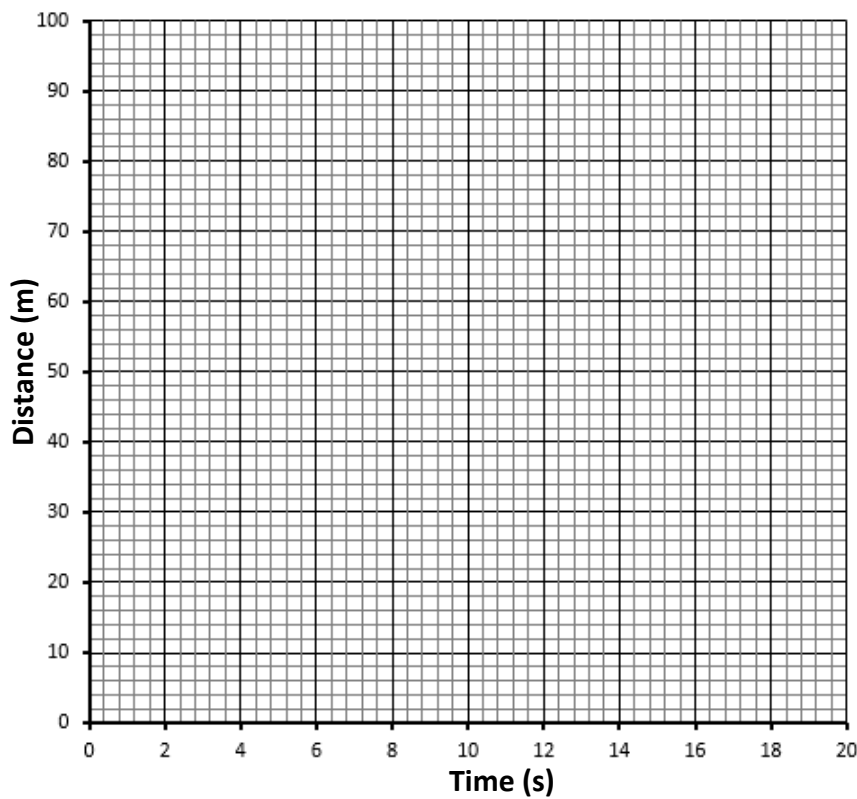

- (ii) Calculate Orla's average speed.

Calculation

- (iii) Which athlete, Orla or Molly, had a constant speed throughout the race?

Explain your answer. _____

(1) (2)

(b) Physics is central to the functioning of many of the pieces of equipment in a children's playground.

(15)

(i) A seesaw is supported by a fulcrum at its centre of gravity.

A boy of weight 400 N sits 2.4 metres from the fulcrum, as shown in the diagram.

Calculate how far from the fulcrum his friend (who is of weight 320 N) should sit, so that the seesaw is balanced.

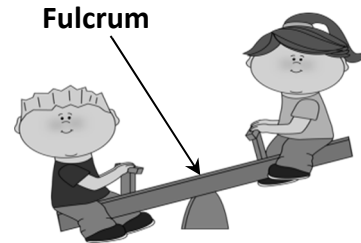

Calculation

(ii) Friction is an important factor on a playground slide.

What is friction?



(iii) What could happen to a child going down a slide if there was too much friction?

(iv) Why might a child go down a slide in a waterpark at a faster speed than a slide in a playground?

For
examiner
use only

(1) (2)

