



# Coimisiún na Scrúduithe Stáit State Examinations Commission

**JUNIOR CERTIFICATE EXAMINATION, 2017**

## **SCIENCE – HIGHER LEVEL**

**MONDAY, 12 JUNE – AFTERNOON, 2.00 – 4.00**

### **INSTRUCTIONS**

1. Write your examination number in the box provided on this page.
2. Answer all questions.
3. Answer the questions in the spaces provided in this booklet. If you require extra space, there is a blank page provided at the back of this booklet.
4. The use of the *Formulae and Tables* booklet approved for use in the State Examinations is permitted. A copy may be obtained from the examination superintendent.

<b>Centre Number</b>
----------------------

<b>Examination Number</b>
_____

<b>For examiner use only</b>	
<b>Section / Question</b>	<b>Mark</b>
<b>Biology</b>	
Q.1 (52)	
Q.2 (39)	
Q.3 (39)	
<b>Chemistry</b>	
Q.4 (52)	
Q.5 (39)	
Q.6 (39)	
<b>Physics</b>	
Q.7 (52)	
Q.8 (39)	
Q.9 (39)	
<b>Total (Paper)</b>	
Bonus for Irish	
<b>Grand Total (Paper) (390)</b>	
<b>Coursework A (60)</b>	
<b>Coursework B (150)</b>	
<b>Grand Total (600)</b>	

# Biology

For  
examiner  
use only

## Question 1

(52)

(1) (2)

(a) (i) Which characteristic of living things allows an organism to release energy from food? \_\_\_\_\_

(ii) Which characteristic of living things allows the continuation of a species?  
\_\_\_\_\_

(b) The diagram shows how a student could demonstrate that exhaled air contains more carbon dioxide than inhaled air.

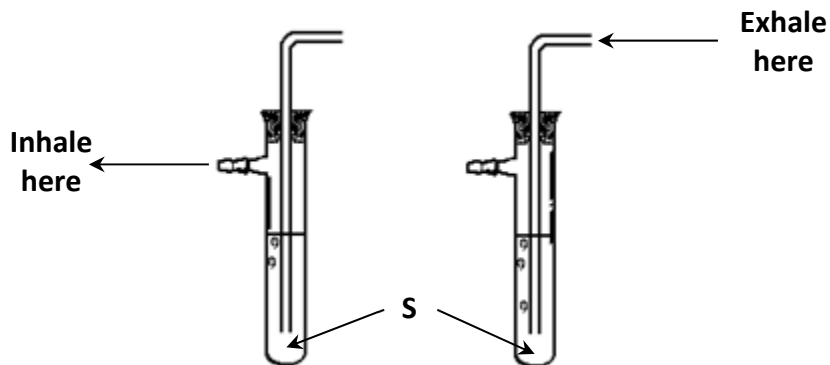

(i) What solution **S** is used to detect carbon dioxide? \_\_\_\_\_

(ii) Name the other waste product of aerobic respiration, other than carbon dioxide.  
\_\_\_\_\_

(c) (i) Why do foxes have large canine teeth?  
\_\_\_\_\_  
\_\_\_\_\_

(ii) Why do rabbits have large incisor teeth?  
\_\_\_\_\_  
\_\_\_\_\_



(d) State a function of the red blood cells and a function of the plasma in the blood.  
Red blood cells \_\_\_\_\_  
Plasma \_\_\_\_\_

(e) The picture shows a nutrient agar dish in which colonies of micro-organisms have grown.

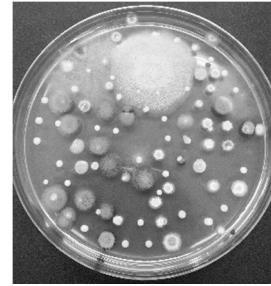

(i) Name one type of micro-organism.

\_\_\_\_\_

(ii) What is the function of the nutrient agar?

\_\_\_\_\_

(f) Distinguish between digestion and excretion.

Digestion \_\_\_\_\_

\_\_\_\_\_

Excretion \_\_\_\_\_

\_\_\_\_\_

(g) Complete the following word equation for photosynthesis.



(h) The diagram shows the human male reproductive system.

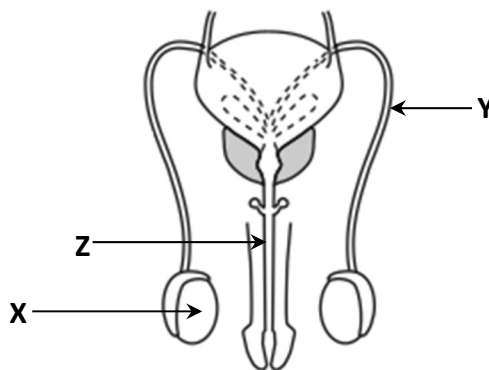

(i) Name the parts labelled X and Y.

X \_\_\_\_\_

Y \_\_\_\_\_

(ii) Name the male gamete produced in X. \_\_\_\_\_

(iii) Name tube Z that is part of the male reproductive system and part of the urinary system. \_\_\_\_\_

(7 × 6 + 1 × 10)

For  
examiner  
use only

(1) (2)

**Question 2**

(39)

For  
examiner  
use only

- (a) A group of students carried out a line transect study to show the distribution of the daisy, a common wildflower plant, in a grassland habitat.



One end of a string was staked next to the trunk of a tree and the other end was staked 8 m away from the tree, as shown.

The string had knots at 1 m intervals. The number of daisy plants touching the string in each 1 m interval (station) is given in the table below.

Station 1 was nearest the tree.

(15)

<b>Station</b>	<b>1</b>	<b>2</b>	<b>3</b>	<b>4</b>	<b>5</b>	<b>6</b>	<b>7</b>	<b>8</b>
<b>Number of daisy plants</b>	<b>0</b>	<b>2</b>	<b>3</b>	<b>5</b>	<b>7</b>	<b>8</b>	<b>7</b>	<b>6</b>

- (i) Using the results in the table, draw a suitable graph to show the relationship between the number of daisy plants and the distance from the tree.

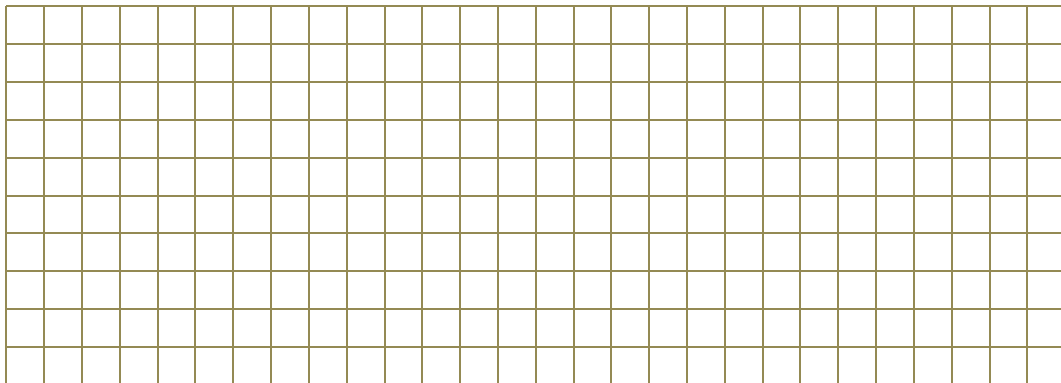

- (ii) Suggest a reason why there were no daisy plants in the first interval (Station 1).

---



---

- (iii) Name another method that could be used to investigate the distribution of the daisy plant in a habitat.

---

(1) (2)

- (b) An experiment was set up to test the action of the enzyme amylase on starch. (15)
- Test tube **X** contained starch solution and amylase.
- Test tube **Y** contained starch solution only.
- Both test tubes were placed in a water bath at 37 °C for ten minutes.

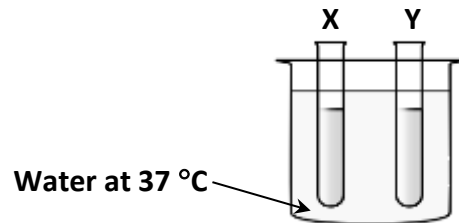

(1) (2)

- (i) Why was the temperature of the water bath set at 37 °C?

---



---

- (ii) After ten minutes, a chemical was used to test for the presence of starch in each test tube.

Name the chemical used. \_\_\_\_\_

- (iii) State the final colour you would expect to see in each of the two test tubes after the addition of this chemical.

**X** \_\_\_\_\_ **Y** \_\_\_\_\_

- (iv) Identify the product of the action of the enzyme amylase on starch.

---

- (c) Fertilisation is the fusion of a male gamete and a female gamete. (9)

- (i) Name the part of the flower that produces the male gamete.

---

- (ii) On the diagram of the flower on the right, label with the letter **F** the arrow that points to the place where fertilisation occurs.

- (iii) Name the stage that follows fertilisation in the lifecycle of a typical flowering plant.

---





(c) The diagram shows the human eye, a sense organ.

(18)

(i) Label with the letter **X** the part of the eye that focuses light onto the retina.

(ii) Name the part of the eye that controls the size of the pupil.

\_\_\_\_\_

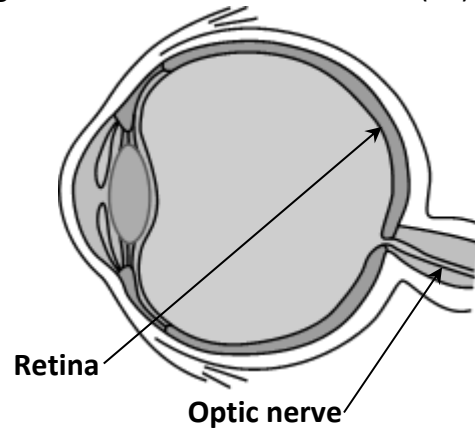

(iii) Place a tick (✓) in the box under the diagram of how an eye appears in bright light.



(iv) What is the central nervous system?

\_\_\_\_\_  
\_\_\_\_\_

(v) Distinguish between sensory nerves and motor nerves.

Sensory \_\_\_\_\_

\_\_\_\_\_

Motor \_\_\_\_\_

\_\_\_\_\_

For  
examiner  
use only

(1)

(2)

# Chemistry

For  
examiner  
use only

## Question 4

(52)

(1) (2)

(a)      **Water**                      **Chlorine**                      **Sodium**                      **Iron sulfide**

Two of the chemicals listed above are elements and two of them are compounds.  
Circle the two compounds.

(b) (i) Identify the state of matter (solid, liquid or gas) that has no shape of its own and cannot be compressed.

\_\_\_\_\_

(ii) What is meant by evaporation?

\_\_\_\_\_

(c)      Air is a mixture of gases.

(i) What is the most abundant gas in air?

\_\_\_\_\_

(ii) The arrangement shown on the right was used to demonstrate the presence of water vapour in air.

What chemical could be used to detect the water droplets?

\_\_\_\_\_

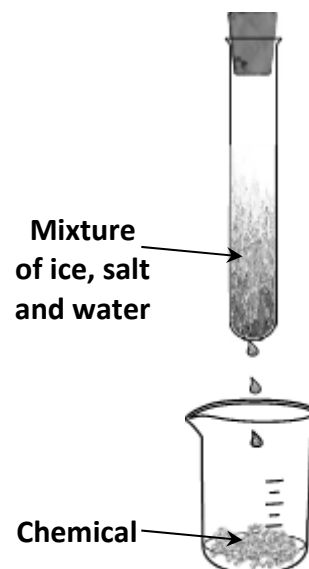

(d) (i) Why is the tripod shown in the diagram usually made of iron?

\_\_\_\_\_

\_\_\_\_\_

(ii) State one method of preventing this piece of equipment from rusting.

\_\_\_\_\_

\_\_\_\_\_





(e) Alkali metals, such as sodium (**Na**), react vigorously with water.

Complete the word equation for the reaction between sodium and water.

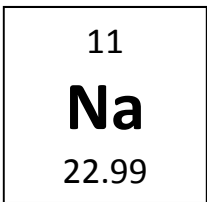

For  
examiner  
use only

(1) (2)



(f) (i) What property of **Cu** makes it suitable for use in electrical wiring?

\_\_\_\_\_

(ii) What property of **Au** makes it suitable for use in jewellery?

\_\_\_\_\_

(g) Methane (**CH<sub>4</sub>**) is an example of a fossil fuel.

Methane is also a hydrocarbon.

(i) Name another fossil fuel. \_\_\_\_\_

(ii) Name one compound formed when a hydrocarbon is burned completely. \_\_\_\_\_

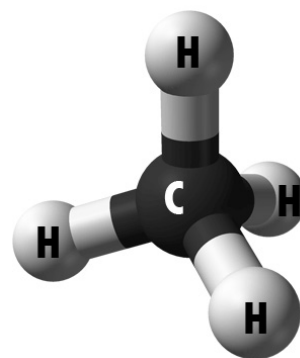

(h) The diagram shows an atom that has seven positive sub-atomic particles.

(i) Name the type of sub-atomic particle that has a positive charge.

\_\_\_\_\_

(ii) Name the type of sub-atomic particle that has a negative charge.

\_\_\_\_\_

(iii) Name the part of the atom where the positive charges are located.

\_\_\_\_\_

(iv) Identify the element whose atom is shown in the diagram.

\_\_\_\_\_

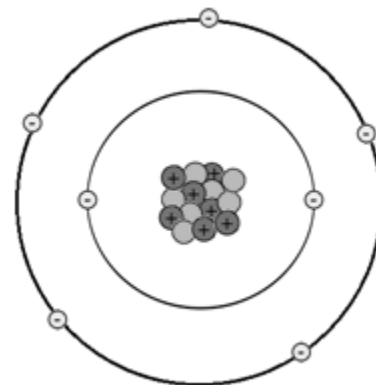

(7 × 6 + 1 × 10)



(c) A student carried out a titration of hydrochloric acid (**HCl**) against sodium hydroxide (**NaOH**) using the apparatus shown. At the start of the experiment a coloured chemical is added to the **NaOH**. (18)

(i) Name the coloured chemical added to the **NaOH**.

\_\_\_\_\_

(ii) What is the purpose of adding this chemical?

\_\_\_\_\_  
 \_\_\_\_\_  
 \_\_\_\_\_

(iii) Name the piece of equipment labelled **X**.

\_\_\_\_\_

(iv) The student noted the volume of **HCl** added to **NaOH** and then repeated the procedure twice more.

The results are shown in the table below.

Titration	Volume of HCl (cm <sup>3</sup> )
1	19.7
2	19.2
3	19.3

Calculate the average volume of **HCl** added.

Calculation

\_\_\_\_\_

\_\_\_\_\_

\_\_\_\_\_

\_\_\_\_\_

\_\_\_\_\_

\_\_\_\_\_

\_\_\_\_\_

(v) Describe the next steps the student would take to prepare a pure sample of sodium chloride (**NaCl**).

\_\_\_\_\_  
 \_\_\_\_\_  
 \_\_\_\_\_  
 \_\_\_\_\_  
 \_\_\_\_\_  
 \_\_\_\_\_  
 \_\_\_\_\_

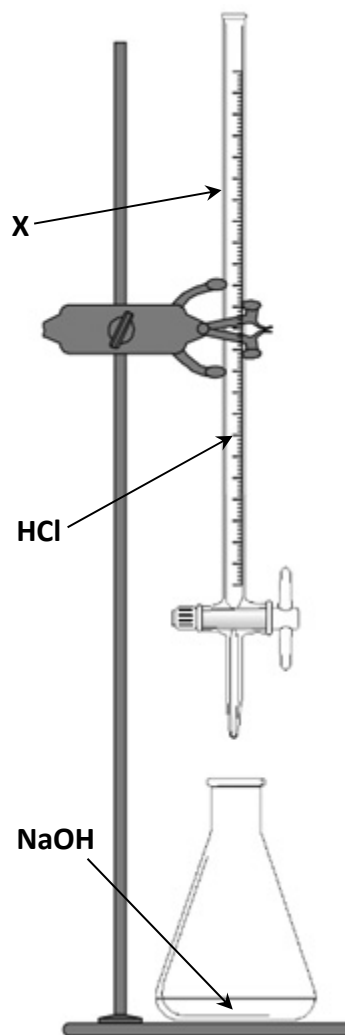

For  
examiner  
use only

(1) (2)

**Question 6**

(39)

For  
examiner  
use only

(a) The atoms in a molecule of oxygen ( $O_2$ ) are covalently bonded.

(18)

(1) (2)

(i) Draw a diagram to show the covalent bonding in  $O_2$ .

In your diagram, include the location of all the electrons.

Diagram

(ii) Ionic bonding is another type of bonding. Magnesium oxide ( $MgO$ ) is an example of a compound that has ionic bonding. Describe how magnesium and oxygen atoms form the ionic compound  $MgO$ .

---

---

---

(iii) Describe how the apparatus shown could be used to test whether a solution contained an ionic compound or a covalent compound.

---

---

---

Why would it be concluded that the solution contained an ionic compound?

---

---

---

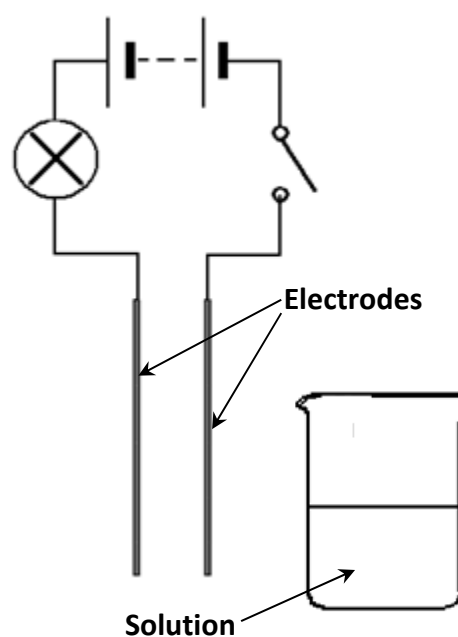

(b) The diagram shows how water can be broken down into its elements using electrolysis. (6)

(i) How could gas **A** be tested to confirm its identity?

\_\_\_\_\_

\_\_\_\_\_

\_\_\_\_\_

(ii) Why was sulfuric acid added to the water at the beginning of the experiment?

\_\_\_\_\_

\_\_\_\_\_

\_\_\_\_\_

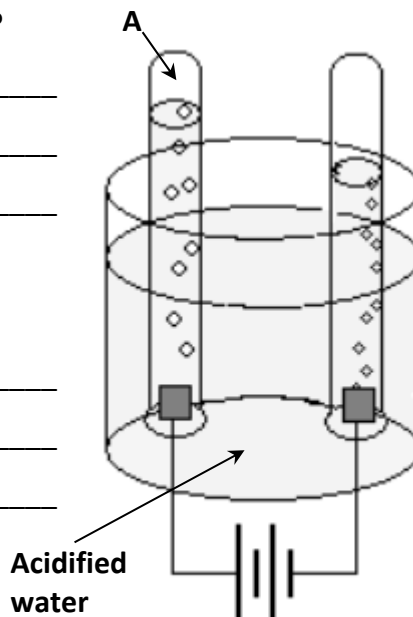

For  
examiner  
use only

(1) (2)

(c) Carbon dioxide gas can be prepared in the laboratory. (15)

(i) Write the balanced chemical equation for this reaction.

Balanced chemical equation

\_\_\_\_\_

\_\_\_\_\_

\_\_\_\_\_

(ii) Carbon dioxide gas was tested with moist blue and moist red litmus paper.

Indicate the final colour of each litmus paper in the box provided.

Tested with:	Moist blue litmus	Moist red litmus
Final colour:		

What conclusion was reached about carbon dioxide gas from this test result?

\_\_\_\_\_

# Physics

For  
examiner  
use only

## Question 7

(52)

(1) (2)

- (a) A flask of warm air with a tube connected to it was heated gently. The top of the tube was then placed under water, as shown.

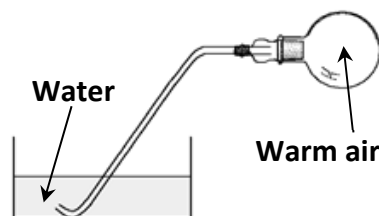

- (i) What is observed as the air cools?  
\_\_\_\_\_

- (ii) Explain this observation. \_\_\_\_\_

- (b) Micheál completes one lap of a running track at a constant speed of  $6 \text{ m s}^{-1}$ .

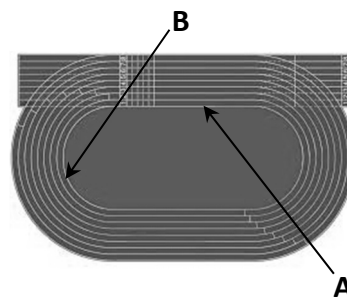

- (i) Does he have the same velocity at **A** and **B**? \_\_\_\_\_

- (ii) Explain your answer. \_\_\_\_\_  
\_\_\_\_\_

- (c) The diagram shows the inside of a three-pin plug.

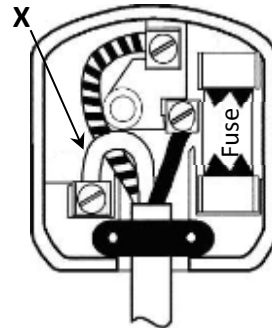

- (i) What colour is the plastic coating on the wire labelled **X**?  
\_\_\_\_\_

- (ii) What is the function of the fuse in a plug?  
\_\_\_\_\_

- (d) A block of ice at  $-20^\circ\text{C}$  was heated at a constant rate. Its temperature was graphed against time, as shown.

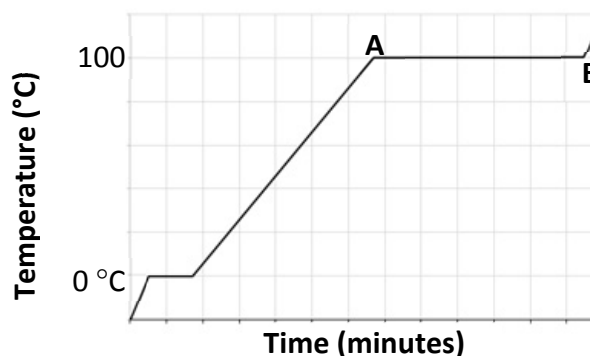

- (i) What change of state occurs between **A** and **B**?  
\_\_\_\_\_

- (ii) What term is used to describe the type of heat gained between **A** and **B**?  
\_\_\_\_\_

- (e) (i) A bar magnet is suspended from a wooden retort stand, as shown. Explain why it always comes to rest with the north pole of the magnet pointing north.

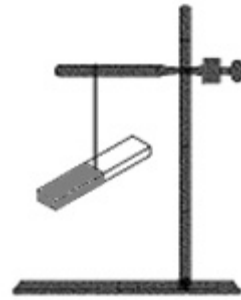

For  
examiner  
use only

(1) (2)

- (ii) What happens when the north pole of another magnet is brought near the north pole of the suspended magnet?

- (f) A spring was suspended and equal weights were added to it, one at a time.

The extension of the spring was noted each time.

When the first weight was added, the extension was 2 cm.



- (i) What is the *total* extension when the second weight is added? \_\_\_\_\_
- (ii) Explain your answer. \_\_\_\_\_

- (g) The force of friction exists between the tyres of a car and the surface of a road.

- (i) How can this force be useful to a driver?

\_\_\_\_\_  
\_\_\_\_\_



- (ii) Explain how friction affects the tyres.

\_\_\_\_\_

- (h) (i) An elephant has a mass of 2400 kg.  
Calculate the weight of the elephant.

Calculation

- (ii) What is the unit of weight?

\_\_\_\_\_

- (iii) Calculate the pressure exerted by the elephant on the ground, assuming that the total area of its feet is  $0.8 \text{ m}^2$ .

Calculation

\_\_\_\_\_

(7 × 6 + 1 × 10)

**Question 8**

(39)

For  
examiner  
use only

(a) The Sun is a luminous object. It is our primary source of energy. (15)

(1) (2)

(i) What is energy? \_\_\_\_\_

\_\_\_\_\_

(ii) Explain why the Sun is considered our primary source of energy.

\_\_\_\_\_

\_\_\_\_\_

(iii) How is heat from the Sun transferred to the Earth?

\_\_\_\_\_

(iv) The Moon is a non-luminous object. Explain how it is often visible at night.

\_\_\_\_\_

(v) Nuclear fusion is the source of the Sun's energy. State one disadvantage of using nuclear energy on Earth.

\_\_\_\_\_

\_\_\_\_\_

(b) The diagram shows the shadow cast by an apple when light shines on it. (6)

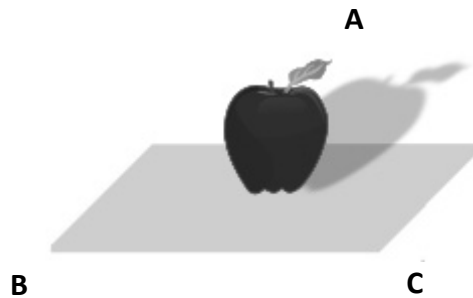

(i) Is the light source that created the shadow located at **A**, **B** or **C**? \_\_\_\_\_

(ii) Explain how the shadow is formed.

\_\_\_\_\_

\_\_\_\_\_



(c) Sound is a form of energy. It is produced by vibrations. (18)

An electric bell is ringing inside a glass jar as shown.

A vacuum pump is used to remove the air from inside the jar.

The bell continues to vibrate.

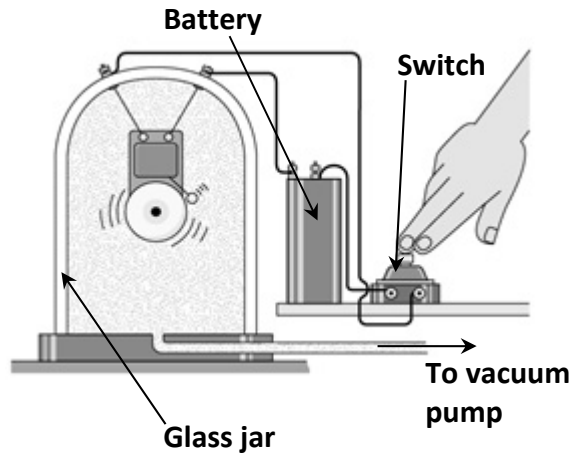

For  
examiner  
use only

(1) (2)

(i) What is observed as a result of the air being removed from the jar?

\_\_\_\_\_

\_\_\_\_\_

(ii) Explain this observation. \_\_\_\_\_

\_\_\_\_\_

(iii) Do light waves *or* sound waves travel faster in air?

\_\_\_\_\_

Describe an example that supports your answer.

\_\_\_\_\_

\_\_\_\_\_

(iv) Commercial fishing boats use sonar to locate shoals of fish. They locate the fish by sending a sound wave from a boat and then detecting the sound wave reflected from the shoal.

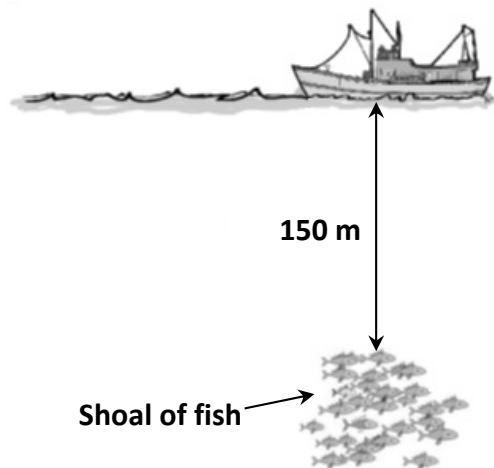

The sound wave from a boat travels to a shoal of fish and its reflection travels back to the boat. The shoal is 150 m below the boat.

The sound wave is detected 0.2 s after it is sent.

Calculate the speed of sound in water.

Calculation

**Question 9**

(39)

For  
examiner  
use only

- (a) A student used the circuit shown to investigate the relationship between the potential difference (voltage) across a resistor and the current flowing through it.

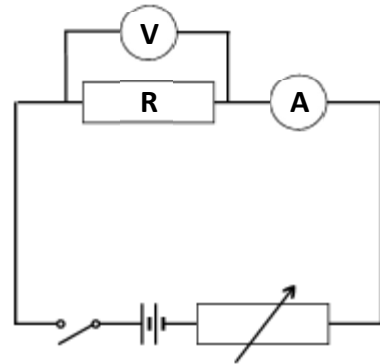

The results are given in the table below. (21)

<b>Voltage (V)</b>	<b>2</b>	<b>4</b>	<b>6</b>	<b>8</b>	<b>10</b>
<b>Current (A)</b>	<b>3.6</b>	<b>7.2</b>	<b>10.8</b>	<b>14.4</b>	<b>18.0</b>

- (i) Draw a graph of voltage against current for these results.

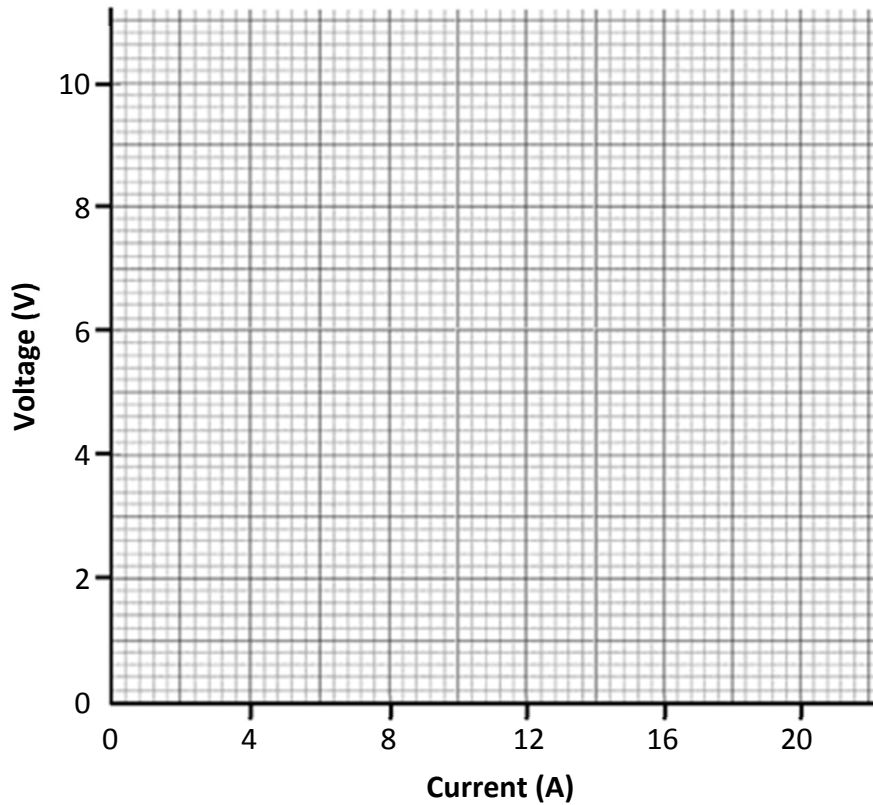

- (ii) What is the relationship between voltage and current shown by your graph?

\_\_\_\_\_

- (iii) Calculate the resistance of the resistor.

Calculation

- (iv) What happens to the resistor when current flows through it?

\_\_\_\_\_  
\_\_\_\_\_

(b) The diagram shows a circuit containing a light-dependent resistor (LDR) attached across an ohmmeter. Light from a lamp shines directly on the LDR.

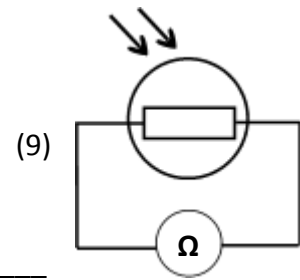

(i) How could the intensity of the light shining on the LDR be changed? \_\_\_\_\_

(ii) Using the axes on the right, sketch a graph to show how the resistance of the LDR is affected by light intensity.

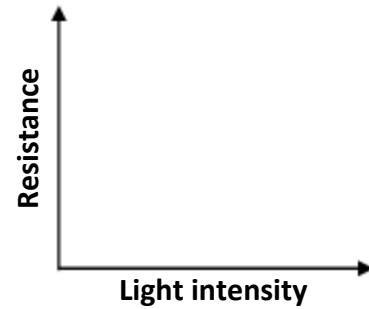

(iii) State one use of an LDR.

\_\_\_\_\_  
\_\_\_\_\_

(c) A student set up the circuits shown to investigate how current flows through a light emitting diode (LED). (9)

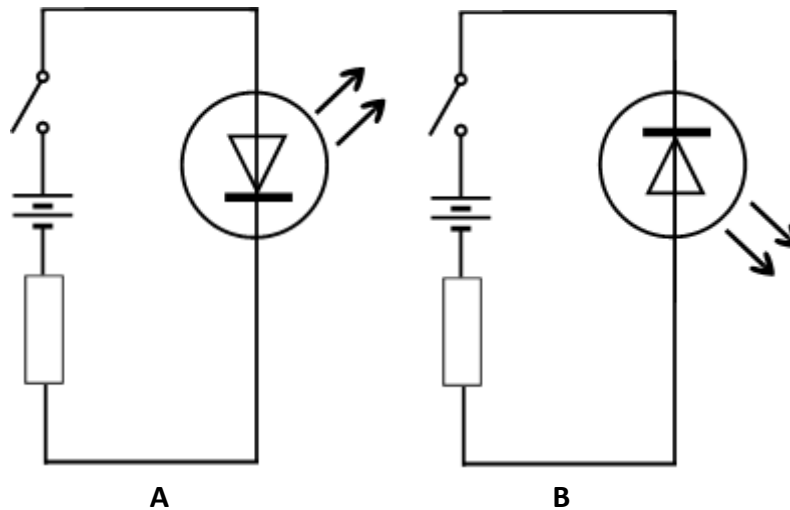

(i) In which circuit, **A** or **B**, would the LED light up when the switch is closed? \_\_\_\_\_

(ii) Explain your answer. \_\_\_\_\_

(iii) State an advantage of using an LED instead of a filament bulb.

\_\_\_\_\_  
\_\_\_\_\_

For  
examiner  
use only

(1) (2)

