



Coimisiún na Scrúduithe Stáit State Examinations Commission

JUNIOR CERTIFICATE EXAMINATION, 2003

SCIENCE – HIGHER LEVEL
(N.B. Not for Science – Local Studies Candidates)

THURSDAY, 12 JUNE - AFTERNOON, 2.00 to 4.30

Section A is on a separate sheet which provides spaces for your answers.
The completed sheet should be enclosed in your answer-book.

SECTIONS B, C, D, E

These sections should be answered in your answer-book.

Answer **ONE** question from each of the Sections **B, C and D**.

All questions carry equal marks.

Answer **TWO** questions from **Section E**. All questions carry equal marks.

SECTION B - PHYSICS (48 marks)

Answer **either** question 4 **or** question 5.

4. (a) Define pressure. (6)
- Give the unit used to measure pressure. (3)
- Why is the water tank in the highest part of the house? (6)
- Describe, with the aid of a labelled diagram, an experiment to show the pressure of the atmosphere. (9)

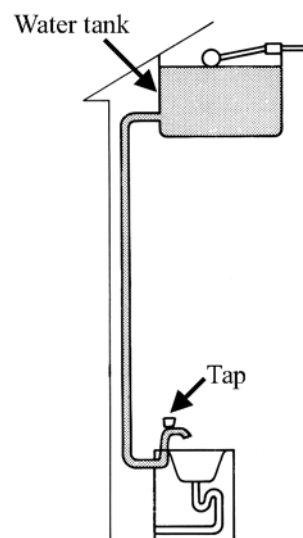

[Turn over

- (b) What happens to the surface of a loudspeaker when it is producing a sound? (3)

Describe an experiment to show that sound is a wave. (12)

What is the wavelength of the wave in the diagram? (3)

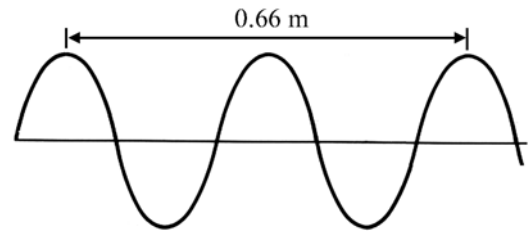

Calculate the frequency of the wave in the diagram if it is moving with a speed of 330 m/s. (6)

5. (a) Name an instrument used to measure electric current. (3)

Copy the circuit diagram shown and include in the diagram the symbol for the instrument that you have named. (6)

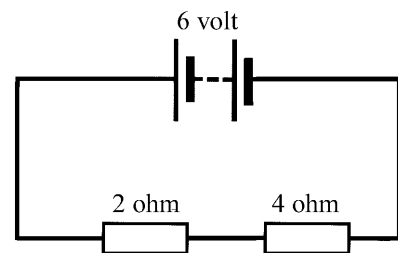

Are the resistors, in the diagram, in parallel or in series? (3)

What is the total resistance of the resistors in the diagram? (3)

Calculate the current flowing in the circuit shown. (6)

The current in the circuit shown flows in one direction only. What is this type of current called? (3)

- (b) What is meant by temperature? (3)

Name a liquid suitable for use in thermometers. (3)

Give a reason why the liquid that you have named is suitable for this purpose. (3)

What happens to the liquid in a thermometer when the temperature increases? (3)

The diagram shows a clinical thermometer.

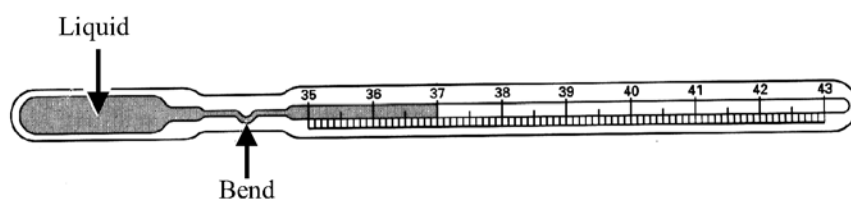

Why is the range of this thermometer only from 35 °C to 43 °C ? (6)

What is the purpose of the bend in the tube? (6)

SECTION C - CHEMISTRY (48 marks)

Answer **either** question 6 **or** question 7.

6. (a) The diagram shows an apparatus used to decompose water by electrolysis.
- (i) Name and give the formula of gas A. (6)
 - (ii) Name and give the formula of gas B. (6)
 - (iii) The volume of gas B is twice that of gas A. What does this tell us about the composition of water? (3)
 - (iv) Which electrode, X or Y, is the anode? Give a reason for your answer. (6)
 - (v) Name a material used for electrodes X and Y. (3)

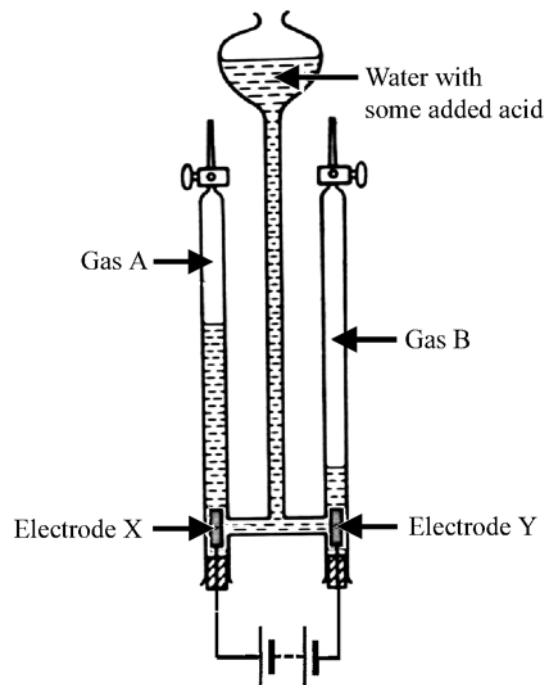

- (b) Draw a diagram showing the arrangement of the electrons in an atom of chlorine (atomic number = 17). (6)
- What is a covalent bond? (6)
- Describe, using a diagram, the bonding in a molecule of chlorine. (6)
- Give two characteristic properties of covalent substances. (6)

[Turn over

7. (a) The apparatus shown is used to burn magnesium in air.

Name the white solid left in the crucible when the reaction is over. (3)

How would you test the white solid to see if it is basic, neutral or acidic?
What result would you expect to get to this test? (9)

Heat is given out when magnesium is burned.
What is the name given to this type of reaction? (3)

Write a chemical equation for the reaction that occurs when magnesium is burned in air. (9)

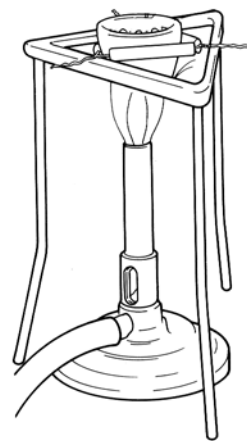

(b) Define oxidation and reduction in terms of electrons. (6)

Name the substance reduced when magnesium is burned in air.
Give a reason for your answer. (6)

(c) What is observed when magnesium reacts with dilute sulphuric acid?
Name one product of this reaction. (9)

Name another element that belongs to the same group in the periodic table as magnesium. (3)

SECTION D - BIOLOGY (48 marks)

Answer **either** question 8 **or** question 9.

8. (a) The diagram shows the reproductive system of the human female.

Name the parts labelled A, B, C and D. (12)

Give one function for each of the parts A, B, C and D. (12)

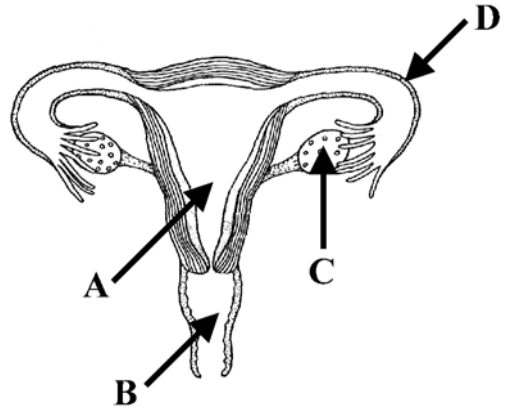

- (b) Give two functions, apart from movement, of the human skeleton. (6)

Name the type of joint shown in the diagram. (3)

Name the parts labelled P and Q. (6)

Explain the role of the parts labelled Q and R in the operation of this joint. (3)

What are antagonistic muscles? (6)

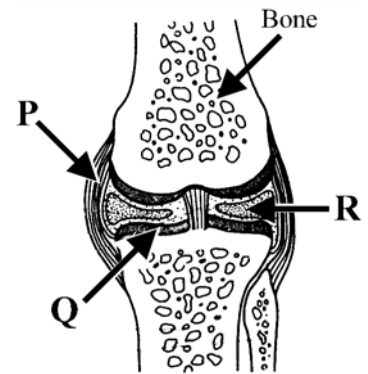

[Turn over

9. (a) A pupil viewed cells of a tissue of an onion using a microscope.

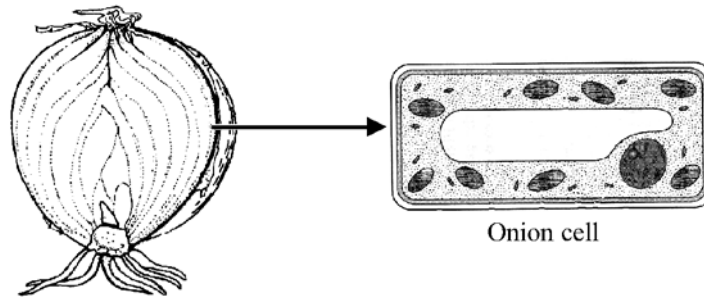

Copy the diagram of the onion cell into your answer-book.

Name and label three parts of the cell in your diagram. (9)

Explain the terms (i) cell and (ii) tissue. (6)

Name two plant tissues.

Give the function of one of the tissues you have named. (9)

- (b) What is a food chain? (3)

The diagram shows a food chain from a garden habitat.

Name: (i) a producer
(ii) a herbivore
(iii) a carnivore
from this habitat. (9)

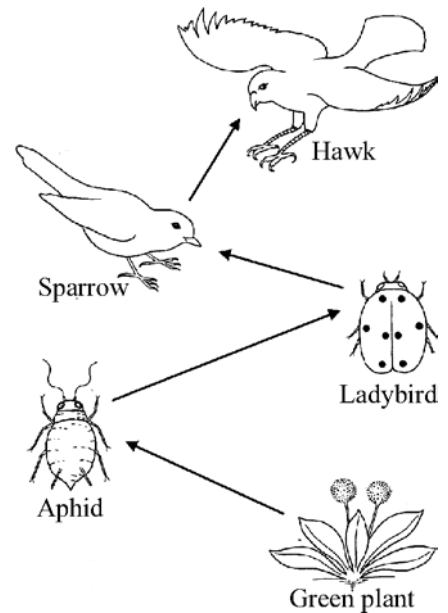

Using this food chain explain what is meant by a pyramid of numbers. (6)

From a habitat you have studied give an example of the interdependence of plants and animals. (6)

SECTION E - APPLIED SCIENCE (72 marks)

Answer **TWO** questions from this section.

10. EARTH SCIENCE. Answer any **two** of the following, (a), (b), (c).

- (a) This photograph, of the planet Jupiter, was taken using the Hubble Space Telescope. Jupiter has sixteen known moons. Explain the underlined terms. (6)

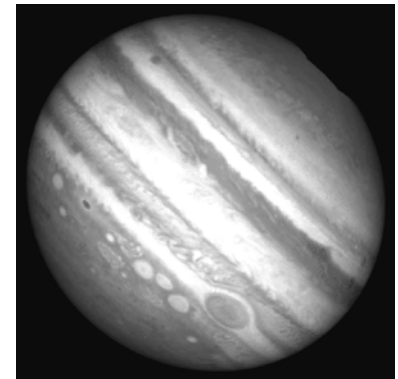

The Earth's moon, viewed from Earth, changes in appearance in a monthly cycle called the phases of the moon. Explain, using a labelled diagram, how the phases of the moon arise. (12)

- (b) Name the type of cloud shown in the photograph. (3)



Explain how clouds are formed. (9)

What is meant by the humidity of air? (6)

- (c) The diagram shows an apparatus used by a pupil to investigate how the volume of a gas changes with temperature.

Give a brief account of the experiment under the headings:

- (i) Measurements (6)
(ii) Graph (6)
(iii) Result / conclusion (6)

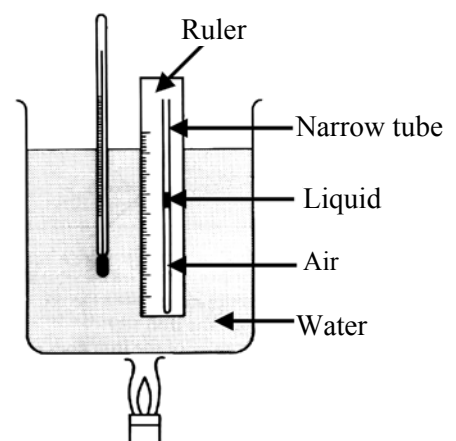

[Turn over

11. **HORTICULTURE.** Answer any **two** of the following, (a), (b), (c).

- (a) The diagram shows a leaf infested with aphids, and a cabbage leaf being eaten by caterpillars.

Give the life cycle of an aphid or the life cycle of the cabbage white butterfly.

(15)

What is meant by secondary infection of a plant?

(3)

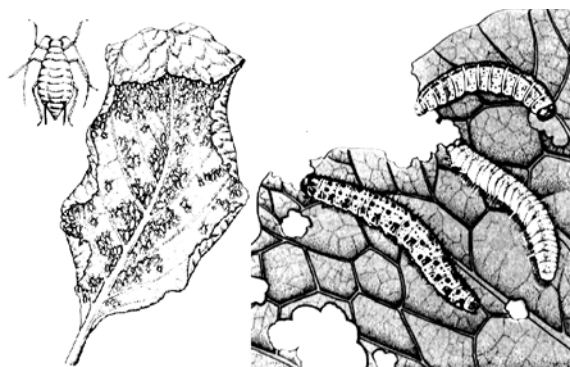

- (b) Give two reasons why air spaces are important in soil. (6)

Describe how to measure the air content of soil. (12)

- (c) Explain the term germination. (6)

Name a plant and outline an experiment to investigate the rate of germination of its seeds. (12)

12. MATERIALS SCIENCE. Answer **both** parts, (a) and (b).

(a) The bicycle is familiar to everyone.

Name two materials used to make a bicycle. (6)

Give one advantage of using each of the materials you have named. (6)

Give two ways in which materials used in a bicycle should be cared for. (6)

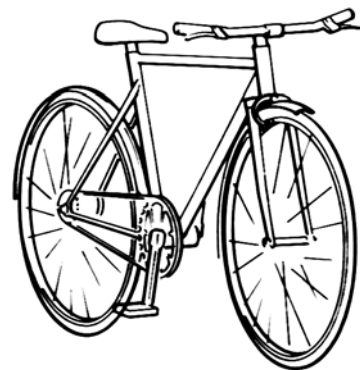

(b) Answer **one** of the following.

(i) PLASTICS

Give the two stages of the production of plastics from crude oil. (6)

Describe an experiment to show that plastics are good heat insulators. (12)

(ii) METALS

Metals can be extracted from their ores. What is an ore? Name a metal mined in Ireland. (6)

Describe an experiment to compare the hardness of two metals. (12)

(iii) TEXTILES

Name one plant and one animal that are sources of textile fibres. (6)

Describe an experiment to compare the absorbency of two fabrics. (12)

(iv) TIMBER

What is the difference between the leaves of hardwood trees and the leaves of softwood trees? (6)

Describe an experiment to investigate the effect of grain direction on the strength of timber. (12)

[Turn over

13. **FOOD.** Answer any **two** of the following, (a), (b), (c).

- (a) The diagram shows carrots, a cheesecake and a trout.

Which of the items in the diagram would be a good source of:

- (i) fibre
- (ii) protein
- (iii) low fat food? (9)

Describe a chemical test to show the presence of protein in a food. (9)

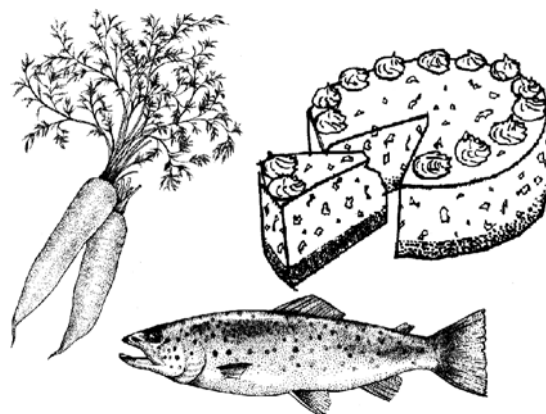

- (b) The photograph is of a farmer planting rice.

Name two factors that make it difficult to distribute food. (6)

Name two other causes of famine in human societies. (6)

Give two effects of famine on people. (6)



- (c) What type of micro-organism is used to make yoghurt? (6)
Give one change that this micro-organism makes to the properties of milk.

Describe an experiment to make yoghurt in a school laboratory. (12)

14. **ELECTRONICS.** Answer **both** parts, (a) and (b).

- (a) The diagram shows a circuit with two-way switching. The circuit shown is open and the bulb is off.

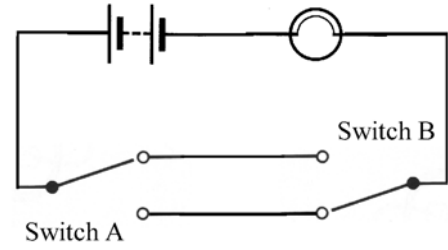

There are two ways in which the bulb can be switched on. Draw diagrams, of the circuit, showing the positions of switches A and B for these two ways. (12)

Draw a diagram of a circuit in which one switch is used to switch on two bulbs. (6)

- (b) The component shown in the diagram is a light dependent resistor or LDR. Give the symbol for this component. (3)



The LDR is part of the circuit shown.

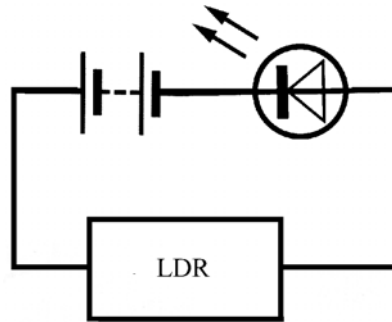

What happens to the LED when the LDR is:

- (i) in bright light
- (ii) covered with black plastic?

Give reasons for your answers. (12)

The LED in this circuit is in forward bias. The cathode of the LED must be connected to the negative terminal of the battery. How would you identify the cathode of an LED? (3)

[Turn over

15. ENERGY CONVERSIONS. Answer both parts, (a) and (b).

(a) The diagram is a cutaway view of a hairdryer.

Write down two *useful* energy changes that occur when a hairdryer is in use. (6)

Give two other *useful* energy changes produced by domestic appliances. (6)

Name two appliances that produce these changes. (6)

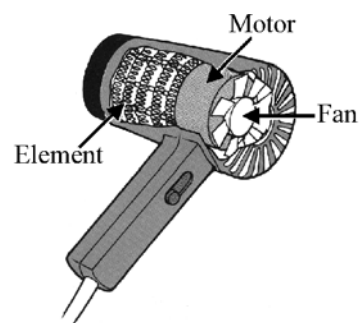

(b) The diagram is of a simple electric motor.

Name parts A and B. (6)

Outline how the motor works. (9)

What happens to the motor if the battery is reversed? (3)

