



Coimisiún na Scrúduithe Stáit State Examinations Commission

JUNIOR CERTIFICATE EXAMINATION, 2016

SCIENCE – HIGHER LEVEL

THURSDAY, 16 JUNE – MORNING, 9.30 to 11.30

INSTRUCTIONS

1. Write your **examination number** in the box provided on this page.
2. Answer **all** questions.
3. Answer the questions in the spaces provided in this booklet. If you require extra space, there is a blank page provided at the back of this booklet.
4. The use of the *Formulae and Tables* booklet approved for use in the State Examinations is permitted. A copy may be obtained from the examination superintendent.

<p>Centre Number</p>

<p>Examination Number</p> <hr style="width: 20%; margin: 10px auto;"/>

For examiner use only	
Section / Question	Mark
Biology	
Q.1 (52)	
Q.2 (39)	
Q.3 (39)	
Chemistry	
Q.4 (52)	
Q.5 (39)	
Q.6 (39)	
Physics	
Q.7 (52)	
Q.8 (39)	
Q.9 (39)	
Total (Paper)	
Bonus for Irish	
Grand Total (Paper) (390)	
Coursework A (60)	
Coursework B (150)	
Grand Total (600)	

Biology

For
examiner
use only

Question 1

(52)

(1) (2)

- (a) All living things are composed of cells, tissues, organs and systems.

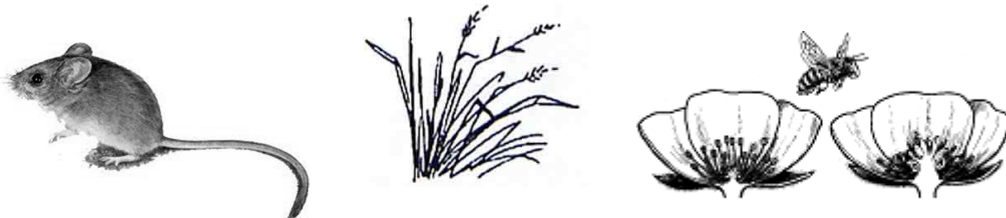

(i) Name one tissue found in the human body. _____

(ii) What is an organ?

- (b) Microbiology is the study of micro-organisms.

(i) What is a micro-organism? _____

(ii) The production of antibiotics is one use of biotechnology. State one other use.

- (c) The blood vessels marked **A** and **B** carry blood away from the heart.

Name **A** and **B**.

A _____

B _____

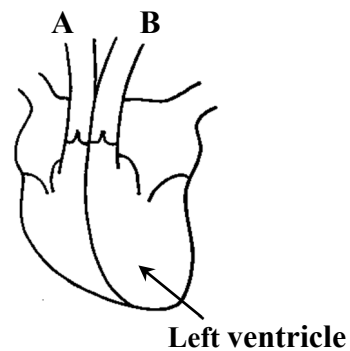

- (d) The diagram given shows the human urinary system.

(i) Name the blood vessel labelled **X** that carries blood rich in waste into a kidney.

(ii) Name **Y**. _____

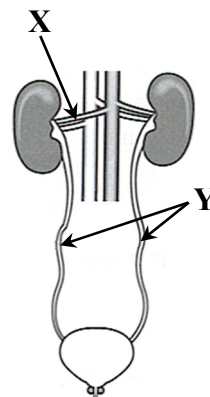

(e) Supplies of food (glucose) and oxygen are needed for aerobic respiration. During this process energy and two waste products are released.

(i) Name one of these waste products. _____

(ii) Name the chemical used to test for the waste product you have named.

(f) The diagram shows a plant which was left near a window for a long period of time.

(i) Name the growth response that caused the plant to grow towards the window. _____

(ii) How is this growth response of benefit to this plant?

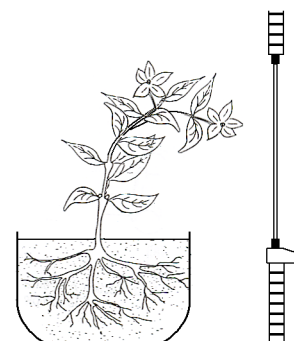

(g) A student used an onion to prepare a slide from plant tissue.

(i) Name the stain used to see the onion cells more clearly.

(ii) What was the purpose of the coverslip?

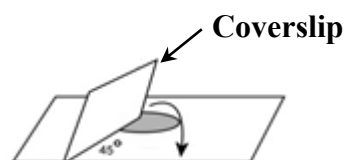

(h) As part of an investigation into the presence of reducing sugars in food, a student tested glucose solution.

(i) Name the chemical added to test for the presence of a reducing sugar.

(ii) What other essential step should be taken?

(iii) How would the solution change to indicate a positive result?

(iv) Describe a control experiment that the student should use in this investigation.

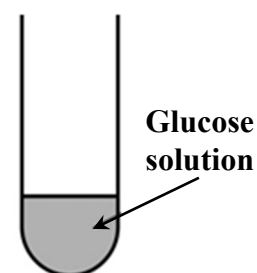

(7 × 6 + 1 × 10)

Question 2

(39)

For
examiner
use only

(a) The diagram shows the human digestive system.

(12)

(1) (2)

(i) To which organ of the human digestive system does the oesophagus carry food?

(ii) State a function of the liver.

(iii) State a function of the large intestine.

(iv) Name a part of the digestive system where both mechanical and chemical digestion occur.

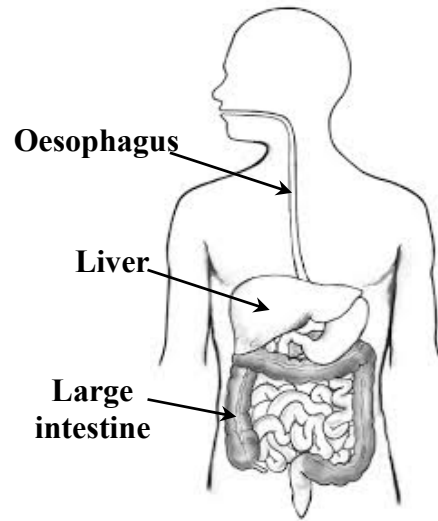

(b) The diagram shows the hinge joint at the elbow.

(12)

(i) Name bone A.

(ii) Where else in the body would you find a hinge joint?

(iii) Ligaments and tendons are found in a hinge joint. What is the function of a tendon?

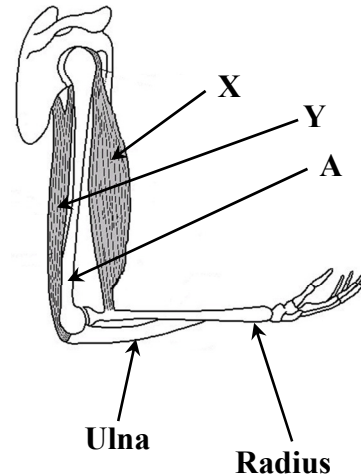

(iv) Muscle X in the diagram has contracted. What happens when muscle Y contracts?

- (c) The diagram shows how the lining of the uterus changes over the course of the human menstrual cycle. (15)

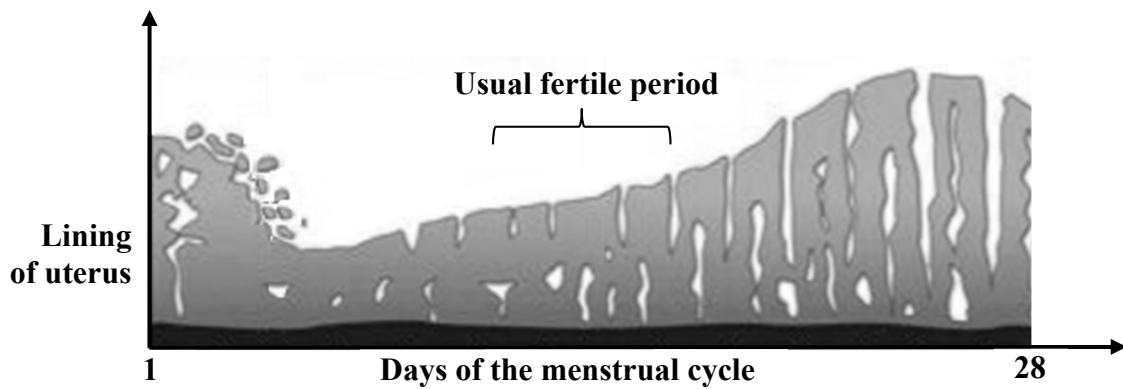

- (i) What process begins on day 1 of the menstrual cycle?

- (ii) What is meant by the fertile period of the menstrual cycle?

- (iii) What happens to the female gamete (egg) during fertilisation?

- (iv) Study the diagram of the human female reproductive system below.

1. Label with the letter **F** the arrow pointing to where fertilisation usually occurs.
2. Label with the letter **P** the arrow pointing to where the foetus usually develops.

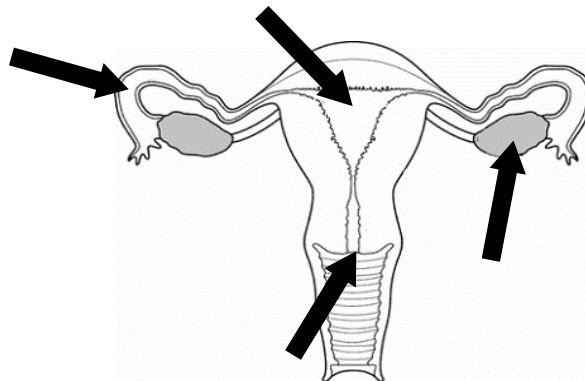

For
examiner
use only

(1) (2)

Question 3

(39)

For
examiner
use only

(a) The diagram below shows a food web from a mixed habitat.

(12)

(1) (2)

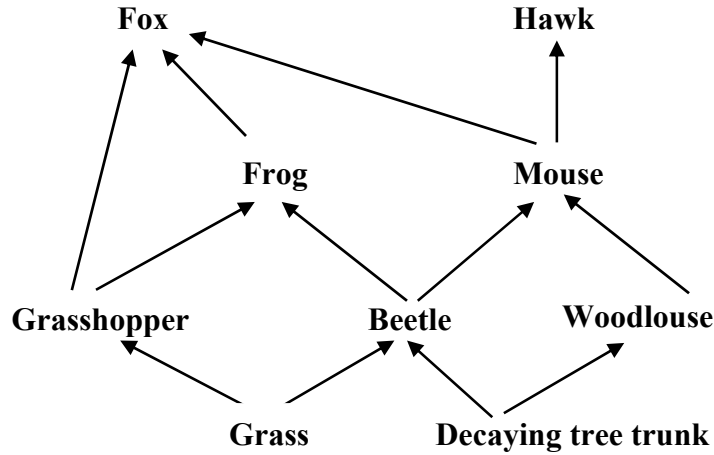

(i) Identify a producer and a decomposer in this food web.

Producer _____ Decomposer _____

(ii) Choose an organism from a named habitat you have studied and describe how it is adapted to living there.

Habitat _____

Organism _____

Adaptation _____

(b) The diagram shows an experiment set up to show the transport of water through certain parts of a plant. A dye was used to show the movement of the water through the plant. (6)



(i) Name the plant tissue of the stem through which water is transported.

(ii) Excess water is lost by transpiration through tiny holes (stomata) in the surfaces of leaves.

Give one other function of a leaf.

(c) Germination is necessary to form new plants from seeds. (21)

The diagram shows the structure of the broad bean seed.

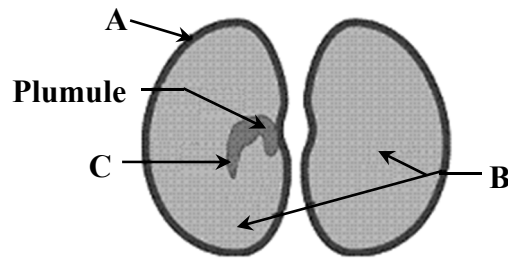

(i) Name parts **A** and **B** of the seed.

A _____

B _____

(ii) Which part of the new plant forms from **C**?

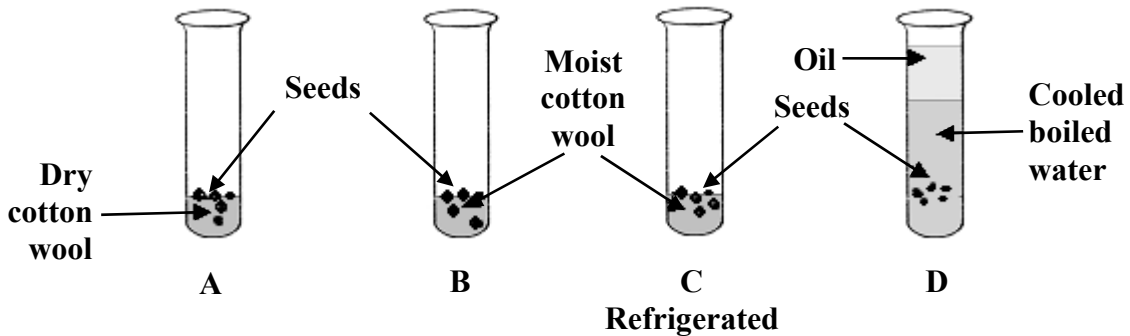

(iii) The diagram below shows four test tubes set up to investigate the conditions necessary for germination. Test tubes **A**, **B** and **D** were left at room temperature and test tube **C** was placed in the fridge and left for the same period of time.



In which test tube would you expect the seeds to germinate? _____

Why is the water boiled and cooled in test tube **D**?

(iv) The diagram shows the fruits of two different plants. Complete the table giving the usual method of dispersal of the seeds contained in each fruit.

Fruit	 Sycamore wing	 Strawberry
Method of dispersal of seeds		

For
examiner
use only

(1) (2)

Chemistry

For
examiner
use only

Question 4

(52)

(1) (2)

- (a) The photograph shows beams made of steel, an alloy widely used in the construction industry.



- (i) What is an alloy? _____

- (ii) Name one other alloy. _____
- (b) Fossil fuels are formed by the decomposition of dead plants and animals.
- (i) Name one example of a fossil fuel. _____
- (ii) Name one compound produced when fossil fuels are burned in oxygen.

- (c) Name each of the metallic elements with the chemical symbols below.

Au _____

Cu _____

Fe _____

- (d) Water molecules consist of two atoms of hydrogen and one atom of oxygen, as shown in the diagram.

- (i) Name the process which uses electricity to separate water into its elements. _____

- (ii) Write down the chemical formula for a molecule of oxygen gas.

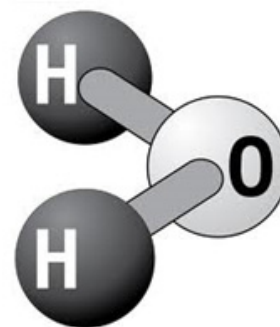

- (e) Two of the following processes are examples of chemical changes and two of them are examples of physical changes.

Underline the two processes which are examples of *chemical* changes.

Shredding of paper

Rusting of iron

Melting of iron

Burning of paper

- (f) Lemon juice has a pH that is less than 7.
(i) Describe how a student could find the pH of lemon juice.



- (ii) Name one material *or* substance which could neutralise lemon juice.

- (g)(i) Identify a metal that reacts with hydrochloric acid (HCl).

- (ii) Name the gas produced when this metal reacts with hydrochloric acid. _____



- (h) The alkali metals are found in Group 1 of the periodic table of the elements.

- (i) Name two of the alkali metals.

1. _____

2. _____

- (ii) Describe one *physical* property of the alkali metals. _____

- (iii) Describe one *chemical* property of the alkali metals. _____

(7 × 6 + 1 × 10)

Question 5

(39)

- (a) A group of students collected four water samples. The samples were investigated to compare, in a fair test, how many soap flakes were needed to form a lather in each. The results are shown in the table below. (18)

	Sample A	Sample B	Sample C	Sample D
Number of soap flakes needed to form a lather	18	34	12	20

- (i) Which one of the samples in the table had the most hardness? _____
- (ii) How would the students have ensured that the test was a fair one?

- (iii) Identify an element whose compounds cause hardness in water. _____
- (iv) A sample of water contained dissolved substances. Describe, with the aid of a labelled diagram, a separation technique that could be used to remove dissolved substances from the sample so that pure water is obtained.

Labelled diagram

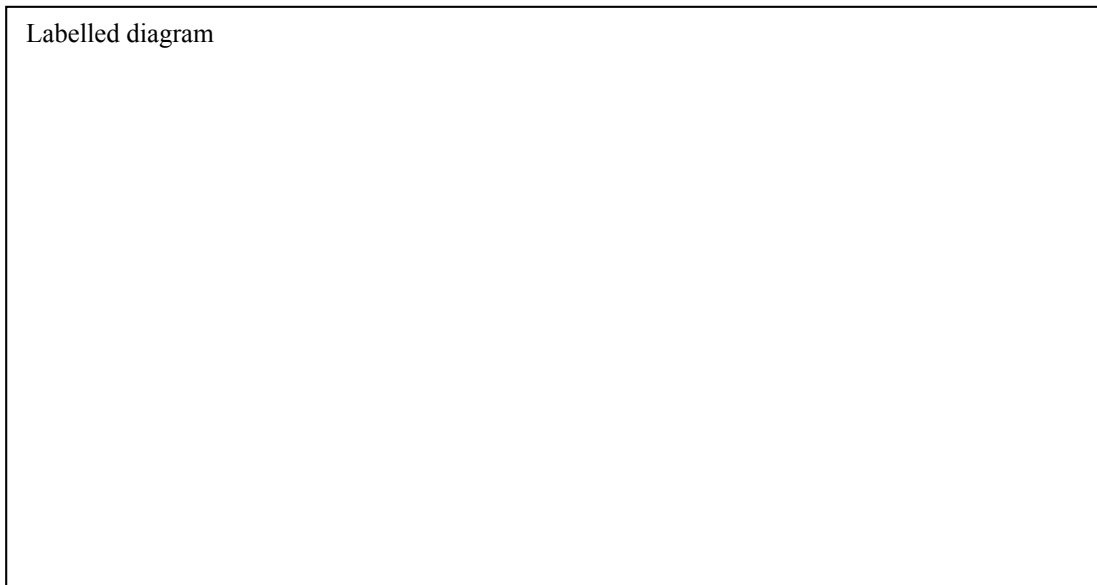

For
examiner
use only

(1) (2)

(b) A group of students investigated the solubility of different substances in water. (9)

(i) What term is used to describe a liquid, such as water, which is used to dissolve substances? _____

(ii) While investigating the solubility of copper sulfate in water, the students found that after adding a large mass of copper sulfate to the water, some of it did not dissolve, even after shaking and stirring. What term is used to describe a solution that contains as much dissolved material as possible?

(iii) Outline the step the students could have taken to make more of the copper sulfate dissolve. _____

(c) The diagram below shows the arrangement of the apparatus used for the preparation of oxygen gas in the laboratory. (12)

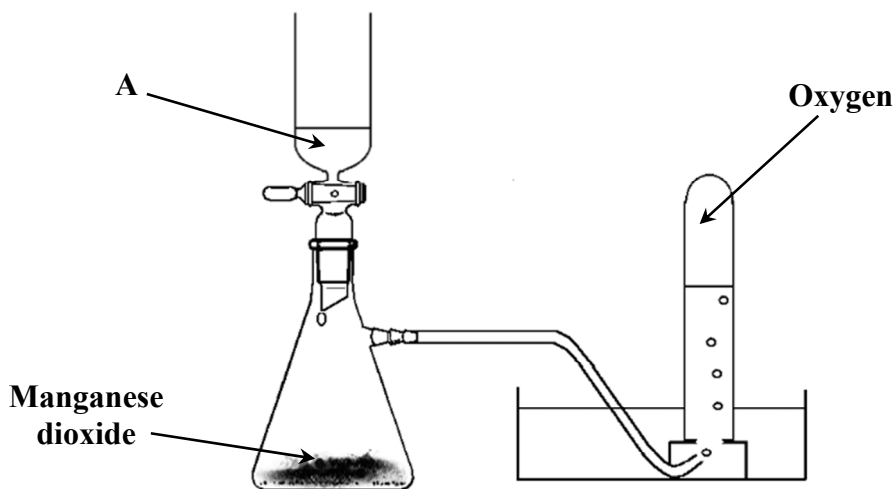

(i) Name the solution labelled A. _____

(ii) Describe the appearance of solution A. _____

(iii) The manganese dioxide speeds up the rate of this reaction but is not used up at the end of the experiment. What name is given to a substance which acts in this way?

(iv) A test tube of oxygen was collected. Two pieces of damp litmus paper (one red and one blue) were then placed into this test tube. Neither changed colour.

What conclusion can be made from this observation?

Question 6

(39)

For
examiner
use only

(a) Children's toys are often made of plastic. (6)

(i) Name one property of plastics that makes them suitable for use in children's toys.

(ii) Name the natural resource used as the raw material in the manufacture of plastics.



(1) (2)

(b) The properties of the states of matter are based on the behaviour of the particles. The diagrams below, labelled **A**, **B** and **C**, represent the three states of matter of the same substance. (9)

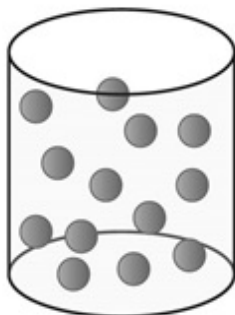

A

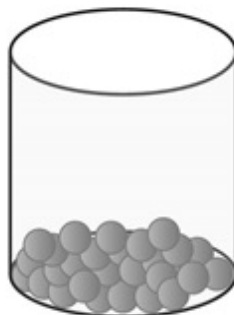

B

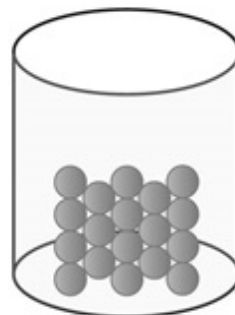

C

Identify each of the states of matter.

A _____

B _____

C _____

- (c) A student researched the element fluorine (F) and found the following information.

(24)

9	F	19
---	----------	----

(1) | (2)

- (i) Name one particular source which the student could have used to find this information. _____
- (ii) Using this information, show in the table below the *number* of each type of sub-atomic particle present in an atom of fluorine. Complete the table to show the *location* (within the atom) of the protons and of the neutrons.

Particle	Number	Location
Proton		
Neutron		
Electron		Electron cloud

- (iii) Name an element which has the same number of electrons in its outer shell as fluorine. _____
- (iv) A sodium atom bonds with a fluorine atom to form the compound sodium fluoride, using a type of chemical bonding called *ionic bonding*. What is ionic bonding?

- (v) Another type of chemical bonding is called *covalent bonding*.
Name a compound that is formed as a result of covalent bonding.

Physics

Question 7

(52)

(1) (2)

- (a) A hotel porter carries a suitcase that weighs 250 N up a flight of stairs 8 m in height.
How much work is done?

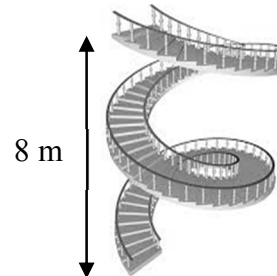

- (b) A cooling curve for a certain mass of molten candle wax is given below.

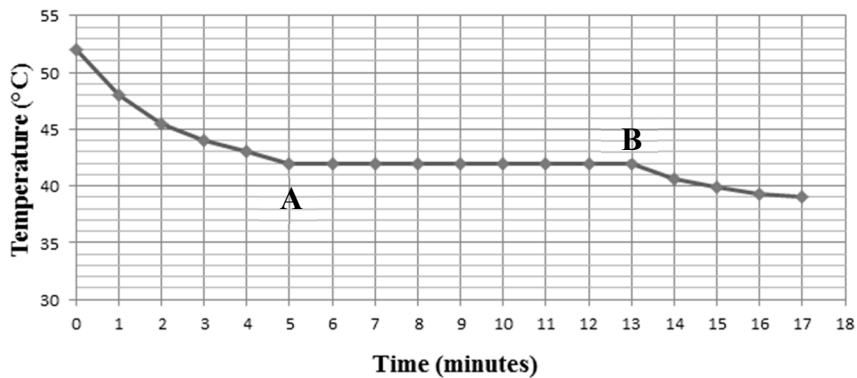

- (i) Why is the temperature on the graph constant between **A** and **B**?

- (ii) Use the graph to find the melting point of candle wax.

- (c) The diagram shows the magnetic field around a bar magnet.

- (i) What are the parts labelled **N** and **S** called?

- (ii) What information is given by the arrows shown on the magnetic field lines?

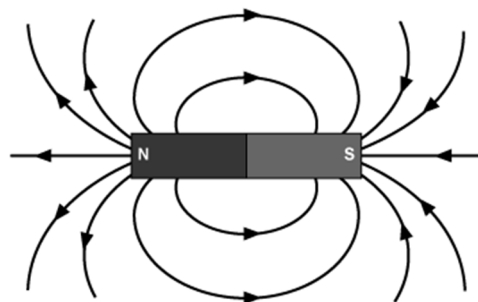

(d) Consider the circuit containing an LED drawn on the right.

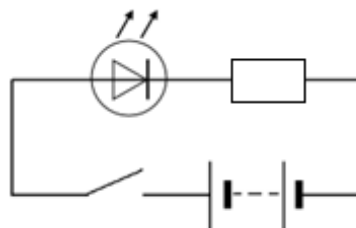

(i) What is observed when the switch is closed?

(ii) What, if any, is the effect of reversing the terminals of the battery?

(e) There are many different forms of energy.

(i) Name the form of energy stored in a battery. _____

(ii) A basketball falls straight through a hoop.

What energy *change* occurs as the ball falls towards the ground?

(f) The diagram shows two test tubes each containing water and a liquid that is insoluble in water.

Give the reason why the water sinks *under* liquid A.

Give the reason why water floats on liquid B.

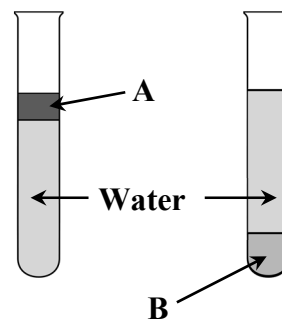

(g) Why are the visual effects of a firework, that explodes at a distance of a few hundred metres from a person, seen a short time before the sound effects are heard?



(h) Examine the weather chart on the right.

(i) What is the lowest pressure value on the chart?

(ii) How does the pressure at point A compare with the pressure at point B?

(iii) **Clearly** mark X on the weather chart where you would expect clear skies and calm, settled weather.

(iv) What is the name of the instrument used to measure atmospheric pressure?

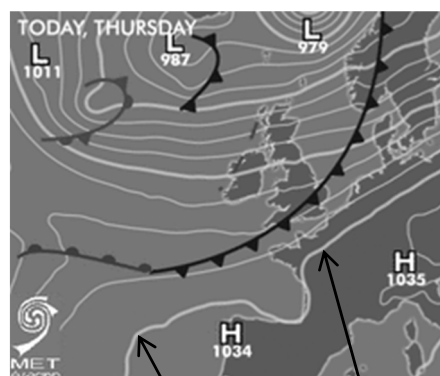

A

B

(7 × 6 + 1 × 10)

Question 8

(39)

For
examiner
use only

- (a) A student set up the experiment shown below to investigate heat conduction. All the rods used had the same length and thickness. A pin was stuck on to the end of each rod. (9)

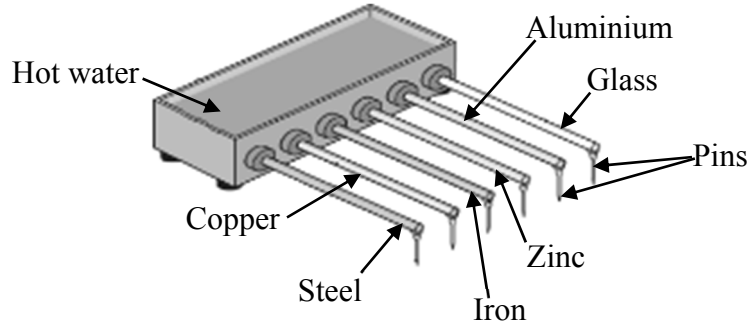

- (i) Suggest a suitable substance to use in the experiment to stick the pins on the ends of the rods. _____
- (ii) The pin on the copper rod was the first to fall off and the pin on the glass rod was the last to fall.

What does this result tell you about copper?

What does this result tell you about glass?

- (b) A student demonstrated expansion and contraction of solids using a ball and ring apparatus like the one shown. (9)

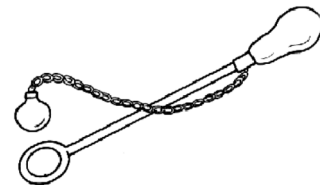

- (i) First the metal ball was passed through the metal ring to prove that it fitted through. How could the student then cause expansion of the ball? _____
- (ii) How could the student prove that the ball had expanded? _____
- (iii) How could the ball be made contract again? _____

(c) The centre of gravity of an object is the point where all its weight appears to act. (21)

(i) Explain how you would find the centre of gravity of an irregularly shaped piece of cardboard like that shown on the right.



You may use a labelled diagram to support your answer.

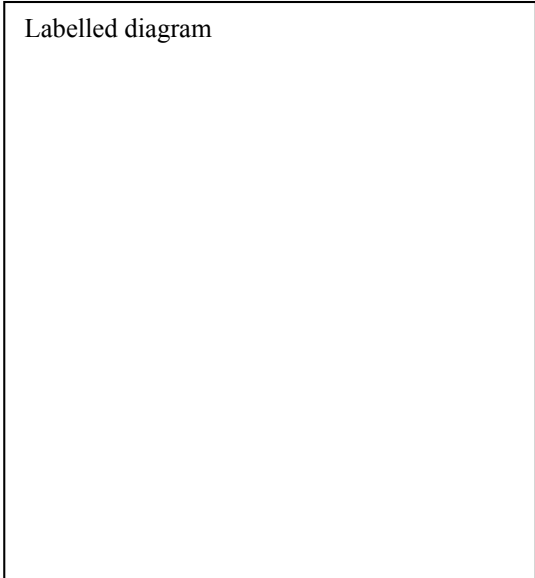

(1) (2)

(ii) Compare the sports car and the bus shown in the photographs on the right.



Give one feature of the design of the sports car that makes it more stable than the bus.



(iii) Indicate which arrow, **A**, **B** or **C**, points to the fulcrum in the diagram on the right showing a lever in use to raise a heavy box.

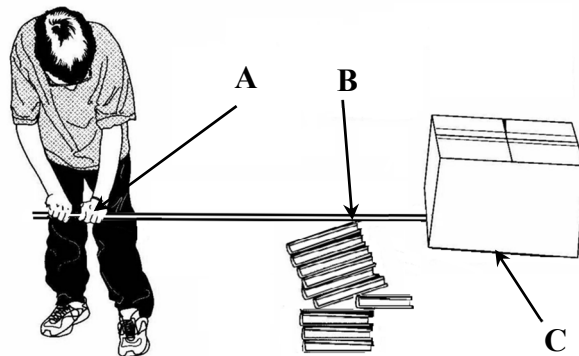

Explain how the law of the lever applies in this example.

Question 9

(39)

(a) The diagram shows an experiment involving light.

(12)

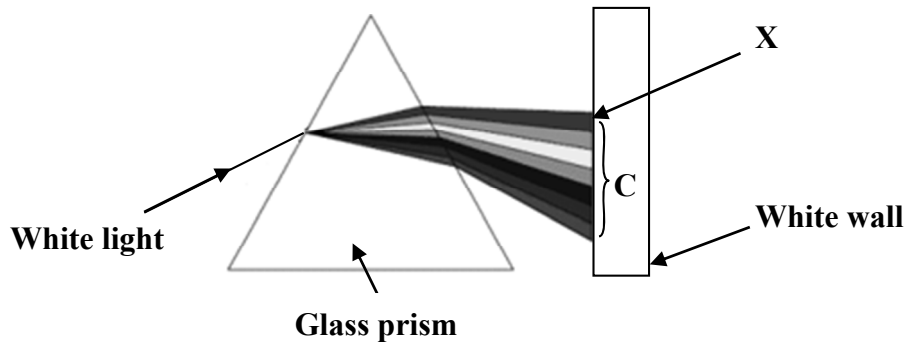

(i) What term is used for the change in direction of the light beam as it enters the prism?

(ii) What term is used for the spreading out of the white light into different colours inside the prism? _____

(iii) What term is used for C the set of different colours of light projected onto the white wall? _____

(iv) What colour appears at the place marked X on the white wall?

(b) A student was asked to test electrical conduction in *paper, copper, silver* and *plastic* and conclude which of these materials were electrical conductors and which were insulators.

(9)

(i) Draw a labelled diagram of the set up (circuit) the student could use.

Labelled diagram

(ii) Based on the circuit you drew above, how could you tell which materials were electrical conductors? _____

For
examiner
use only

(1) (2)

- (c) In a 'soapbox' competition a driver raced against the clock in a straight line down a track in a vehicle with no power source. (18)



(1) (2)

The table below gives the distances (from the start) travelled by the driver at various times during the run down the track.

Time (s)	0	4	8	12	16	20
Distance (m)	0	6	14	24	44	100

- (i) Use this table to draw a distance against time graph.

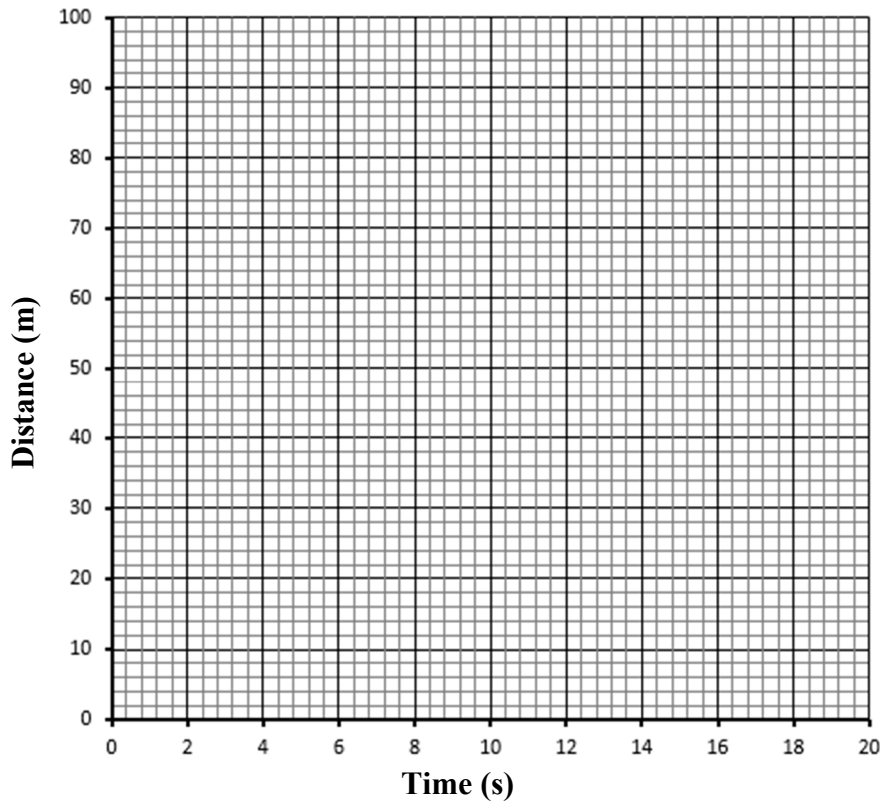

- (ii) Find the time taken for the vehicle to travel 80 m. _____

- (iii) Calculate the average speed of the vehicle during the last four seconds of the run.

- (iv) What is the difference between speed and velocity?
