

**WARNING**

**You must return this paper with your answer-book, otherwise marks will be lost.**

AN ROINN OIDEACHAIS AGUS EOLAÍOCHTA

JUNIOR CERTIFICATE EXAMINATION, 2002

**SCIENCE – HIGHER LEVEL**  
(N.B. Not for Science – Local Studies Candidates)

THURSDAY, 13 JUNE – AFTERNOON, 2.00 to 4.30

**SECTION A (144 marks) TO BE ANSWERED BY ALL CANDIDATES.**

(See separate sheet for Sections B, C, D and E.)

Answer *each* of the questions 1, 2 and 3. There are **TEN** parts in each question. Answer any **EIGHT** parts. All questions carry equal marks. Answer the questions in the spaces provided. Return this Section of the examination paper. Enclose it in the answer-book you use in answering the other Sections.

1. Answer **eight** of the following, (a), (b), (c), etc.

- (a) The diagram shows three solids floating in water. Which solid has the lowest density? Give a reason for your answer.

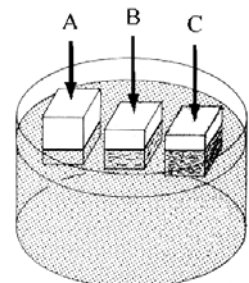

Solid \_\_\_\_\_

Reason \_\_\_\_\_

- (b) Give one advantage and one disadvantage of friction.

Advantage \_\_\_\_\_

Disadvantage \_\_\_\_\_

- (c) Calculate the momentum of a car of mass 850 kg moving with a velocity of 10 m/s.

\_\_\_\_\_

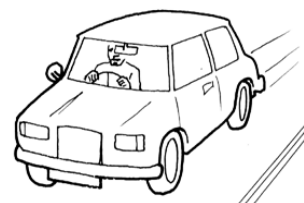

(d) Give two uses of radioactive substances.

Use one \_\_\_\_\_

Use two \_\_\_\_\_

(e) Why is the heating element of an electric kettle as close as possible to the bottom of the kettle?

\_\_\_\_\_  
\_\_\_\_\_

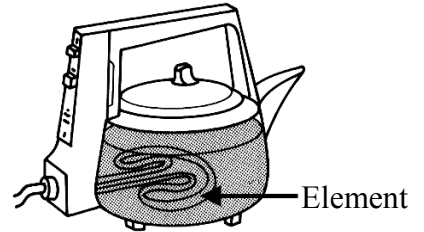

(f) The diagram shows a drawing pin being pushed into a board. Why is the pressure exerted on the head of the pin less than that exerted by the point on the board?

\_\_\_\_\_  
\_\_\_\_\_

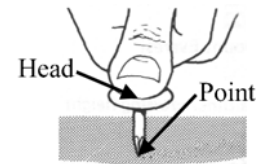

(g) Give a property of oven gloves that allows the girl to handle the hot bread.

Property \_\_\_\_\_

Name a material with this property.

Name \_\_\_\_\_



(h) The design of a 13 A plug includes safety features, e.g. a fuse. Give two other safety features of the 13 A plug.

Feature one \_\_\_\_\_

Feature two \_\_\_\_\_

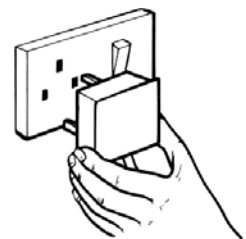

(i) Label the poles on the magnet A suspended by thread in the diagram shown below.

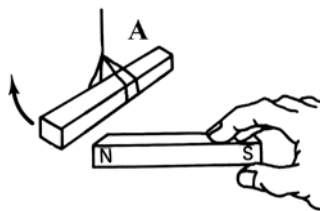

(j) Give two differences between heat and temperature.

Difference one \_\_\_\_\_

Difference two \_\_\_\_\_

(8 × 6)

2. Answer **eight** of the following, (a), (b), (c), etc.

- (a) Give two reasons why we should reduce our use of fossil fuels as an energy source.

Reason one \_\_\_\_\_

Reason two \_\_\_\_\_

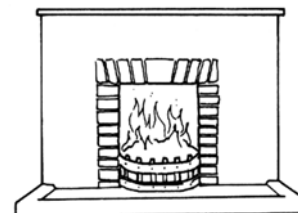

- (b) What is meant by mass number?

\_\_\_\_\_  
\_\_\_\_\_

- (c) How would you test a sample of hard water to see if the hardness was temporary or permanent?

\_\_\_\_\_  
\_\_\_\_\_

- (d) Name two different types of fire extinguisher.

Type one \_\_\_\_\_

Type two \_\_\_\_\_



- (e) What adjustments are necessary to get the hottest flame from a Bunsen burner?

Adjustment one \_\_\_\_\_

Adjustment two \_\_\_\_\_

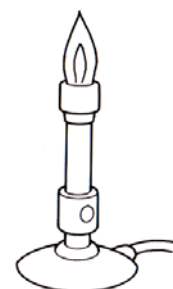

- (f) Explain how an ion is formed from an atom.

\_\_\_\_\_  
\_\_\_\_\_

- (g) Name a metal that could be used for the positive electrode of the simple cell shown.

Name of metal \_\_\_\_\_

What is the liquid in simple cells called?

Name of liquid \_\_\_\_\_

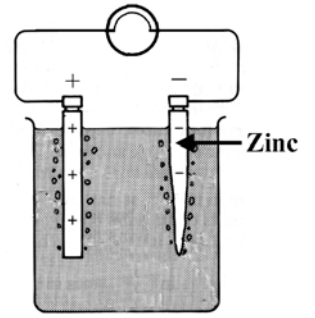

- (h) In a calcium atom how many shells (orbits) have electrons in them?

Number of shells (orbits) \_\_\_\_\_

Give the number of electrons in the outer shell (orbit) of a calcium atom.

Number of electrons \_\_\_\_\_

40
<b>Ca</b>
20

- (i) What is the pH scale?

\_\_\_\_\_  
\_\_\_\_\_

- (j) Define the term neutralisation.

\_\_\_\_\_  
\_\_\_\_\_

(8 × 6)

3. Answer **eight** of the following, (a), (b), (c), etc.

- (a) Underline the parts, which are found in plant cells but **not** in animal cells.

cell wall      cytoplasm      nucleus      cell membrane      vacuole

- (b) Name the instrument shown in the diagram.

Name \_\_\_\_\_

Give one use that you have made of this instrument in the school laboratory.

Use \_\_\_\_\_



- (c) Pupils set up the experiment shown in the diagram. Some time later they compared the strength of the bones. What result would you expect?

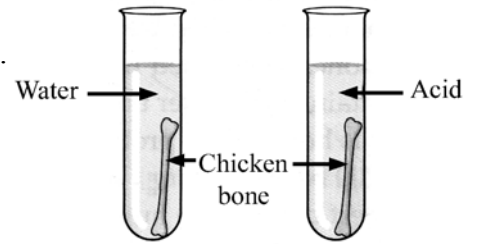

Result \_\_\_\_\_  
 \_\_\_\_\_

Give a reason for your answer.

Reason \_\_\_\_\_

- (d) Where is the organ shown located in our bodies?

Location \_\_\_\_\_

Name a substance excreted by this organ.

Substance \_\_\_\_\_

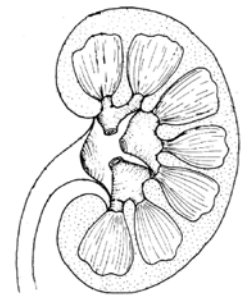

- (e) In a woodland food chain to what feeding (trophic) levels do the hazel tree and the mouse belong?

Mouse \_\_\_\_\_

Hazel tree \_\_\_\_\_



- (f) Pond weed was left in a sunny place and produced a gas as shown. Name the gas and give a test for this gas.

Name \_\_\_\_\_

Test \_\_\_\_\_  
 \_\_\_\_\_

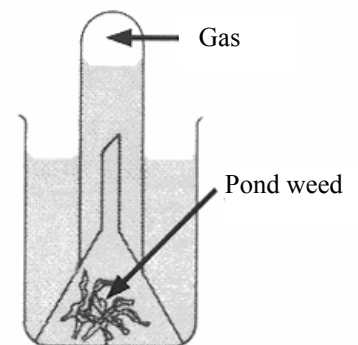

- (g) A pupil exhaled a number of times into the apparatus shown. A colourless liquid appeared in the tube. What does this say about the composition of exhaled air?

\_\_\_\_\_

\_\_\_\_\_

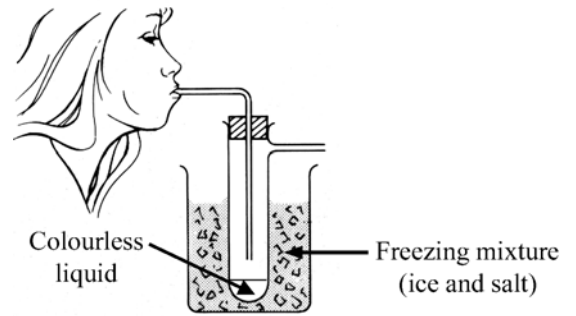

- (h) Sensory nerves carry electrical messages from \_\_\_\_\_ to \_\_\_\_\_

- (i) Name the tree whose leaf is shown opposite.

Name \_\_\_\_\_

Give one reason why trees are important.

\_\_\_\_\_

\_\_\_\_\_

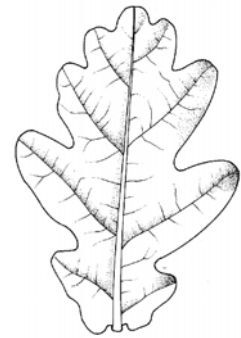

- (j) Name the apparatus shown in the diagram.

Name \_\_\_\_\_

What is the apparatus used for?

Use \_\_\_\_\_

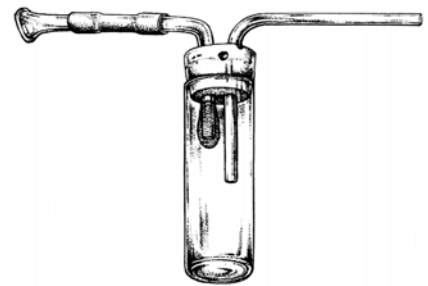

(8 × 6)

## JUNIOR CERTIFICATE EXAMINATION, 2002

**SCIENCE – HIGHER LEVEL**  
 (N.B. Not for Science – Local Studies Candidates)

THURSDAY, 13 JUNE – AFTERNOON, 2.00 to 4.30

**Section A** is on a separate sheet which provides spaces for your answers.  
The completed sheet should be enclosed in your answer-book.

**SECTIONS B, C, D, E**

These sections should be answered in your answer-book.

Answer **ONE** question from each of the Sections **B, C and D**.

All questions carry equal marks.

Answer **TWO** questions from **Section E**. All questions carry equal marks.

<b>SECTION B - PHYSICS (48 marks)</b>
---------------------------------------

Answer **either** question 4 **or** question 5.

4. (a) Define force. (6)

Calculate the moment of the force acting on the spanner in the diagram. (6)

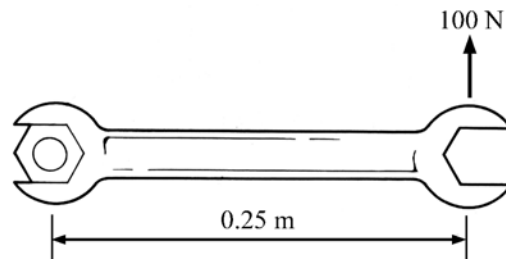

Define work. Name the unit used to measure work. (6)

Calculate the work done by the man, shown in the diagram, pushing the trolley for 200 m.

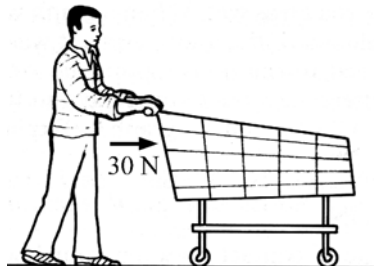

(6)

- (b) Describe, with the aid of a labelled diagram, an experiment to show that sound needs a medium in which to travel. (12)

What is meant by the frequency of a wave? (3)

A ship sends out a sonar (high frequency sound) pulse. Half a second later the echo is detected.

The speed of sound in water is 1500 m/s.

How deep is the water under the ship? (9)

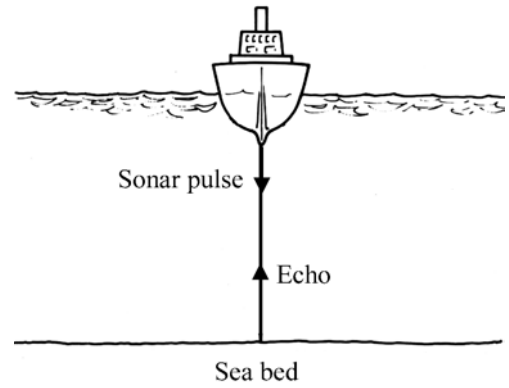

5. (a) What is electric current? (6)

Electric current produces magnetic forces. The diagram shows a battery connected to a wire that passes through a card. The card is at right angles to the wire.

Copy the diagram into your answer-book. Show on the diagram:

- (i) the direction of the electric current  
(ii) a magnetic field line, including its direction, on the card. (9)

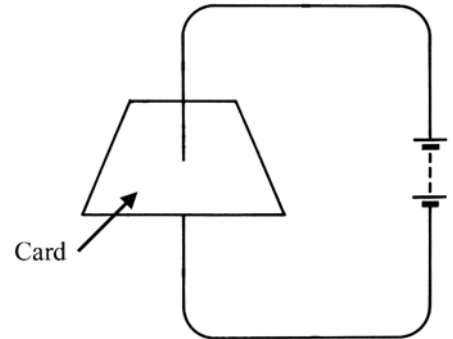

Describe an experiment to show another named effect of electric current. (9)

Give a use in the home of the effect of electric current that you have named. (3)

- (b) Describe a simple experiment to show that light travels in straight lines. (9)

A pupil made the periscope shown in diagram A using two mirrors and some card. Diagram B is a simpler version of A.

Copy diagram B into your answer-book and complete the ray of light to the eye. (6)

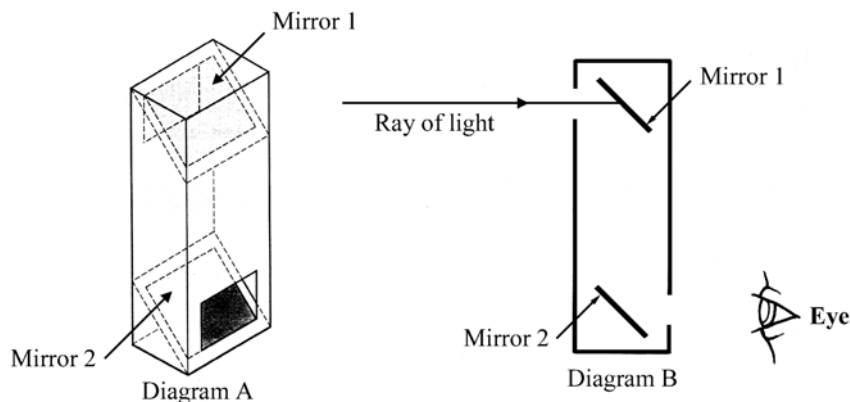

Name two complementary colours of light. (6)



**SECTION C - CHEMISTRY (48 marks)**

Answer **either** question 6 **or** question 7.

---

6. (a) The diagram shows the apparatus used to prepare carbon dioxide. Liquid A is allowed to drop onto solid B.

Name a suitable liquid (A) and a suitable solid (B) that could be used for the preparation of carbon dioxide. (6)

Write a chemical equation for the reaction of liquid A with solid B. (12)

Give a test for carbon dioxide. (6)

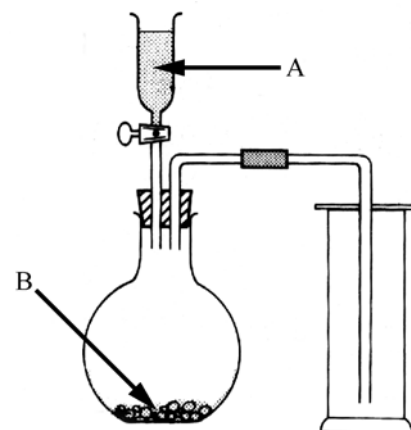

- (b) The diagram shows an experiment to investigate the rusting of iron.

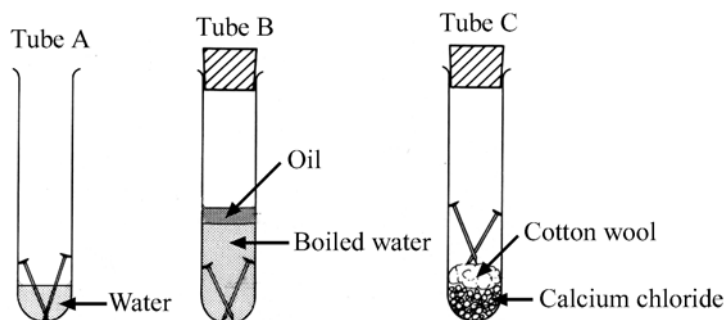

Bright (clean) iron nails were used in each tube.

Why were boiled water and oil used in tube B? (6)

What is the function of the calcium chloride in tube C? (6)

After a few days the nails in tube A were rusted while the nails in tubes B and C were not rusted.

What does this experiment tell us about the conditions needed for rusting? (6)

Give two ways of preventing iron rusting in everyday life. (6)

7. (a) Name the method of separation of mixtures shown in the diagram. (3)

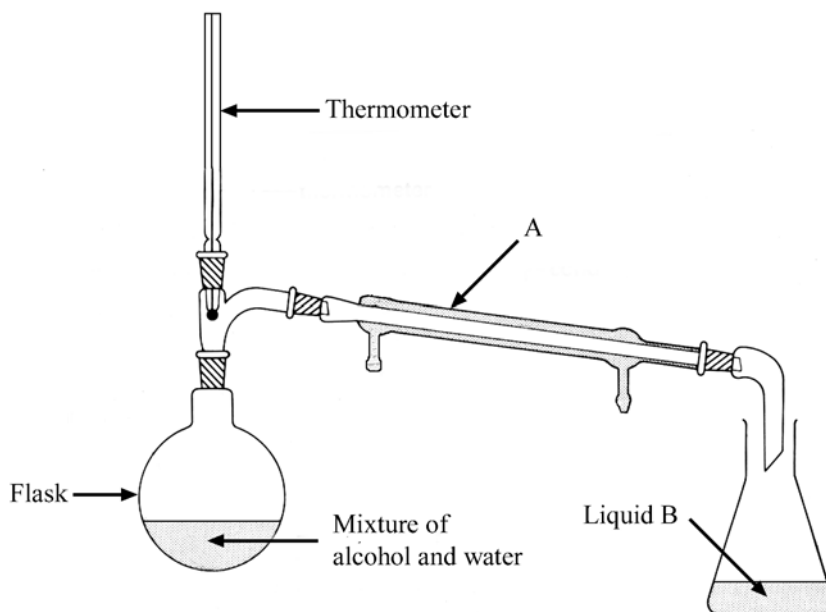

- Name the part labelled A. (3)
- How does the design of A enable it to carry out its function? (6)
- Identify liquid B. (3)
- What is the purpose of the thermometer? (6)
- Name two changes of state that take place in this apparatus. (6)
- (b) What is a chemical reaction? (6)
- Give the term for the release of heat by a chemical reaction. (3)
- Name two substances that react chemically together with the release of heat. Write a chemical equation for the reaction of the two substances that you have named. (12)

**SECTION D - BIOLOGY (48 marks)**

Answer **either** question 8 **or** question 9.

---

8. (a) The diagram shows the human heart and some related blood vessels.

Blood vessels A and B carry blood from the heart.

What are blood vessels like A and B called? (3)

Part D collects blood which is returned to the heart from the body by blood vessel C.

Name the type of vessel labelled C. (3)

Name the part of the heart labelled D. (3)

Give two differences between vessels that carry blood from the heart, e.g. A and B, and vessels that carry blood to the heart, e.g. C. (6)

Explain how white blood cells and platelets protect us. (6)

Give one way that we can care for our heart. (3)

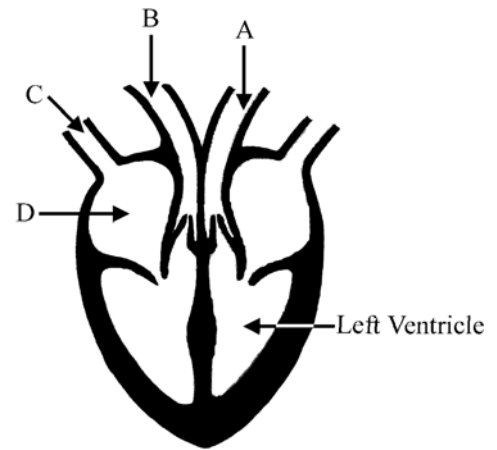

- (b) Part of the human breathing system is shown in the diagram.

What is the function of the tube labelled A? (6)

Name the tiny air tubes like the one labelled B. (3)

Name and describe the structure found at the end of each of these tiny air tubes. (6)

What is the name given to the blood vessels that cover the structure you have described? (3)

Give two ways in which the composition of the blood is changed by its passage through the lungs. (6)

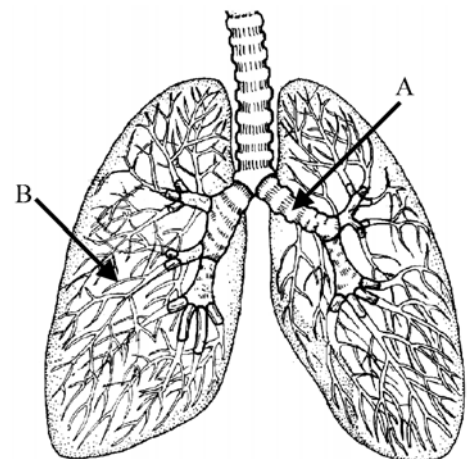

9. (a) The diagram shows a transpiring plant.

Give a factor that affects transpiration rate. (3)

Name the transport tissue that carries water up plants. (3)

Describe an experiment to show the movement of water in a plant. (9)

Tell how to use a quadrat to estimate the frequency of each type of plant in a habitat on the DAFOR scale. (9)  
(D-dominant, A-abundant, F-frequent, O-occasional, R-rare)

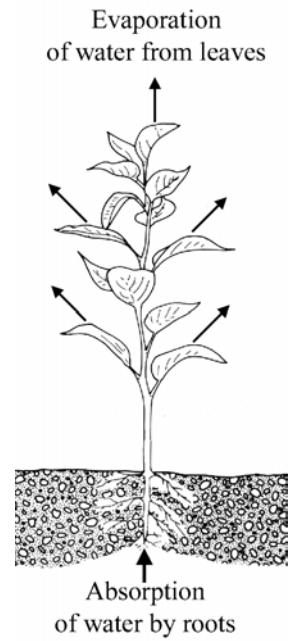

(b) Name a tropism that could cause the radicle (young root) of the germinating seed to grow down as shown in the diagram. (3)

What stimulus could cause the shoot to grow up as shown? (3)

List three conditions that are necessary for a living seed to germinate. (9)

Outline an experiment to show that one of the conditions that you have listed above is essential for germination. (9)

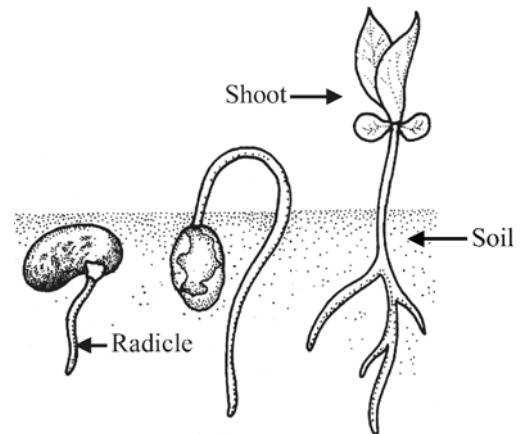

**SECTION E – APPLIED SCIENCE (72 marks)**

Answer **TWO** questions from this section.

---

**10. EARTH SCIENCE.** Answer any **two** of the following, (a), (b), (c).

(a) The picture shows the solar eclipse of 21 June 2001 as seen from Africa.



Describe how a solar eclipse happens. (9)

Explain why we have seasons on earth. (9)

(b) What is the solar system?  
Show, using a diagram, the location of the earth in the solar system. (9)

Compare the earth with the moon under each of the following headings:  
(i) surface gravity, (ii) surface temperature, (iii) atmosphere. (9)

(c) The diagram shows land and sea breezes.

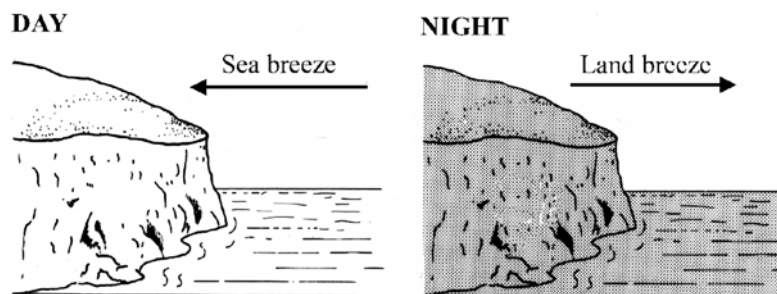

Explain why a breeze comes from the sea to the land during the day. (9)

Explain why a breeze goes to the sea from the land at night. (9)

**11. HORTICULTURE.** Answer any **two** of the following (a), (b), (c).

- (a) Distinguish between a compost and a soil. (3)
- Why are air spaces important in soils and composts? (3)
- How do earthworms improve the quality of soil? (3)
- What is meant by hydroponics? (9)
- (b) Name a plant and describe how to take, prepare and root a cutting from it. (12)
- Give one advantage and one disadvantage of using cuttings as a means of propagating plants. (6)
- (c) Give two steps that should be followed, to get the best results, when harvesting flowers. (6)
- Why are cut flowers kept moist? (3)
- How might the cut surfaces of flowers be treated? (3)
- Name two substances that could be added to the water in which cut flowers are kept so as to make them last longer. (6)

**12. MATERIALS SCIENCE.** Answer **both** parts, (a) and (b).

- (a) The table of common materials shown is not complete.  
Copy the table into your answer-book and complete it by entering your answers in the empty boxes.

Material	Named Example	Use
Textile		clothing
Plastic		
Metal	copper	

(12)

What is an alloy? (6)

- (b) Answer **one** of the following.

(i) PLASTICS

Name a source of hydrocarbons used in the manufacture of plastics.  
What is the origin of the source that you have named? (6)

Describe an experiment to compare the heat insulating ability of two plastics. (12)

(ii) METALS

In what form are most metals found on earth?  
Why do most metals occur in this form? (6)

Outline an experiment to compare the densities of two metals. (12)

(iii) TEXTILES

Give two ways of protecting fabrics. (6)

Describe how you would investigate the resistance to wear of two fabrics. (12)

(iv) TIMBER

Give two ways of protecting timber. (6)

Describe how to investigate the bending strength of two woods. (12)

**13. FOOD.** Answer any **two** of the following, (a), (b), (c).

(a) Why do we need fibre in our diet? (3)

The list of ingredients that follows is from a can of peas:  
Peas, Water, Fructose, Salt, Glucose, E142.

What type of additive is E142? (3)

Name two other additives used in this product. (6)

Give one advantage and one disadvantage of the use of additives in food. (6)

(b) Name two products that include fermentation in their manufacture. (6)

Describe, with the aid of a labelled diagram, an experiment to show fermentation. (12)

(c) Give two reasons why food is preserved for human consumption. (6)

Outline the pasteurisation process. (12)



14. **ELECTRONICS.** Answer **both** parts, (a) and (b).

(a) Name the component labelled A in the circuit diagram. (3)

Give a use for component A. (3)

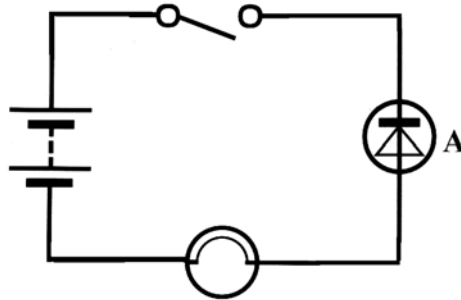

Explain why the lamp does not light when the switch is closed, assuming that all of the components are in working order. (6)

What change would you make to the circuit so that the lamp will light when the switch is closed? (6)

(b) The diagram shows a circuit for a simple heat detector.

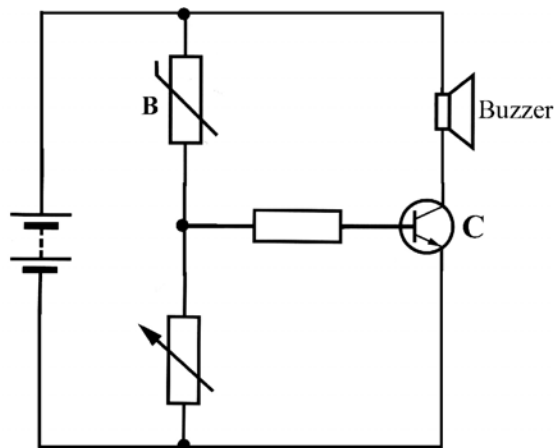

Name the components labelled B and C. (6)

Explain, briefly, how this heat detector works. (12)

**15. ENERGY CONVERSIONS.** Answer **both** parts, (a) and (b).

(a) The diagram shows a hydroelectric power station.

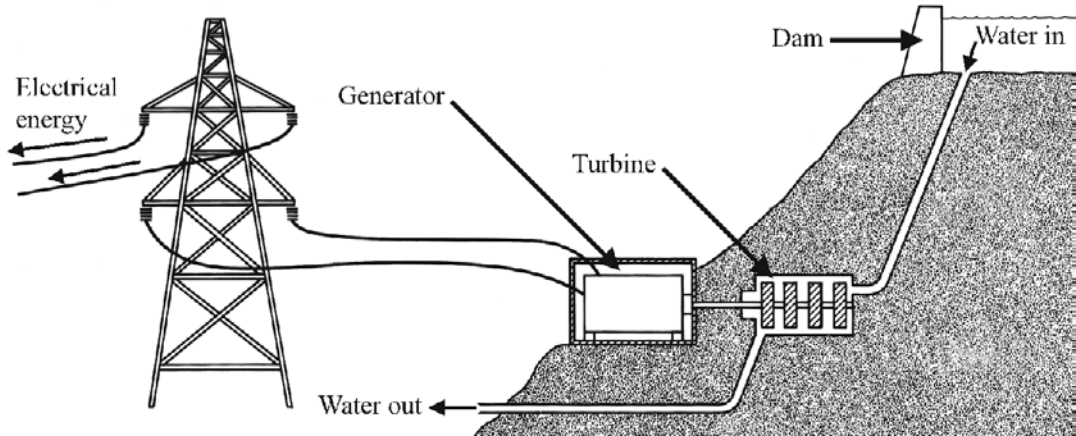

Name the type of energy that the water has because it is held behind the dam. (3)

Give two energy changes that occur in the hydroelectric power station. (6)

Outline how the generator works. (9)

(b) Draw a labelled diagram of a transformer. (9)

What are transformers used for? (6)

Name a household appliance that contains a transformer. (3)