



Coimisiún na Scrúduithe Stáit  
State Examinations Commission

Leaving Certificate Examination 2020

# Computer Science

Sections A & B

Higher Level

1 hour 30 minutes

130 marks

Examination number					

Centre stamp
--------------

For Examiner use only	
Section	Mark
A	
B	
C	
<b>Total</b>	

## Instructions

There are **three** sections in this examination. Section A and B appear in this booklet. Section C is in a separate booklet that will be provided for the computer-based element.

Section A	Short Answer Questions	60 marks	12 questions
Section B	Long Questions	70 marks	3 questions
Section C	Programming	80 marks	1 question

Answer all questions.

Calculators may **not** be used during this section of the examination.

The superintendent will give you a copy of page 78 (Logic Gates) of the *Formulae and Tables* booklet on request. You are not allowed to bring your own copy into the examination.

Write your answers for Section A and Section B in the spaces provided in this booklet. There is space for extra work at the end of the booklet. Label any such extra work clearly with the question number and part.

Answer all twelve questions.

### Question 1

Given the following JavaScript variable declarations, state the result of each of the JavaScript expressions in the table below.

```
let a = 5;
let b = 2;
```

Expression	Result
<code>a * b</code>	
<code>a ** b</code>	
<code>a / b</code>	
<code>b % a</code>	
<code>++a</code>	

### Question 2

Many modern laptops have a hard-disk drive (HDD) which can exceed 1TB in capacity. If you are buying a laptop you may also have the option of a solid-state drive (SSD) with a capacity of 512GB.

(a) In terms of storage capacity, what do the letters GB and TB stand for?

GB:
TB:

(b) Assuming that neither cost nor capacity were issues, explain why you might opt for the SSD rather than the HDD.

**Question 3**

The program counter is a special register in the processor of a computer. Outline the purpose of the program counter.

**Question 4**

The World Wide Web (WWW) and the network infrastructure that supports it allow for seamless transmission of data such as web pages, voice applications and streaming services. This is all possible due to the protocols that it uses.

**(a)** When referring to World Wide Web infrastructure, what is meant by the term *protocol*?

**(b)** State the name and purpose of **one** such protocol.

Name:
Purpose:

**Question 5**

The half-adder logic circuit shown below generates two outputs, S and C, from two inputs, A and B.

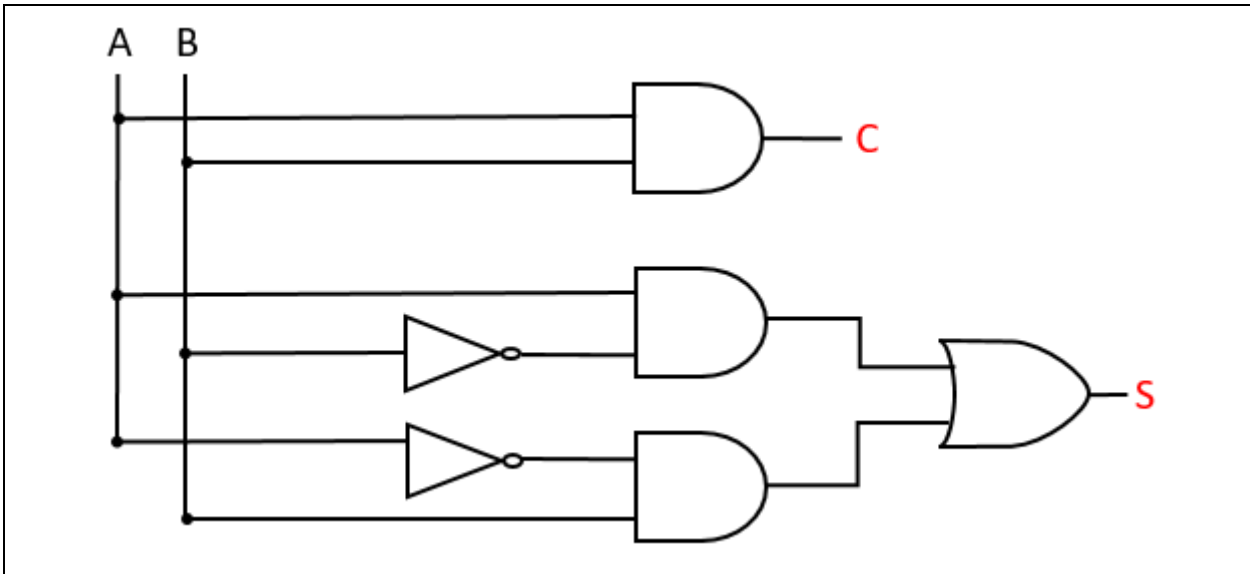

**(a)** What is the value of C when the inputs A and B are both 0?

**(b)** What is the value of S when the inputs A and B are both 1?

**Question 6**

The American Standard Code for Information Interchange (ASCII) is a character encoding standard adopted by the Institute of Electrical and Electronics Engineers (IEEE) in 1963.

**(a)** Why are encoding standards such as ASCII important?

**(b)** State **one** limitation of ASCII.

**Question 7**

The 8-bit binary representation for the ASCII character *K* is shown below.  
Convert this binary number to hexadecimal notation.

0 1 0 0 1 0 1 1
-----------------

### Question 8

The diagram below sets out the operation of the bubble sort algorithm to sort the list of integers [8, 5, 9, 7, 6]. The algorithm works by scanning over the data in four passes. The diagram is complete for pass 1 and started for pass 2.

Complete the diagram for passes 2, 3 and 4. You only need to fill in the numbers.

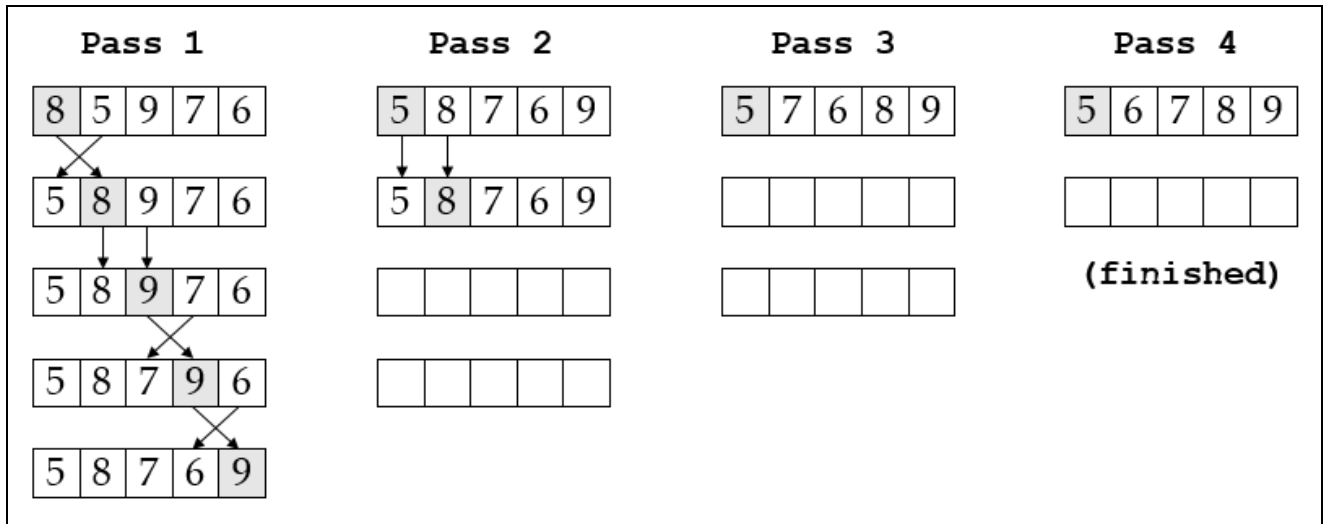

### Question 9

The data set below shows the raw data collected from the result of a 100m school race.

Surname	Gender	Age	Time
Murphy	M	17	13.12
Ogene	M	16	12.14
Ogene	M	16	12.14
Mc Intyre	F.	17	12.87
Lopez	F	-18	14.01
	F	17	1 329
McCarthy	M	77	13.65
Ó Brádaigh	f	16	13.09

List **three** problems with the data in the data set.

1.
2.
3.

### Question 10

The illustrations below show HTML code and the resulting web page as it would be displayed in a typical web browser. Some of the code has been replaced with the numbers 1 – 4.

```
< 1 >
<head>
  <title>School Canteen</title>
</head>
<body>
  <h1> 2 </h1>
  < 3 >
    <li>Burger</li>
    <li>Fish</li>
    <li>Pasta</li>
  </ 3 >
  <p>Click <a 4 ="desserts.html">here</a> for desserts.</p>
</body>
</html>
```

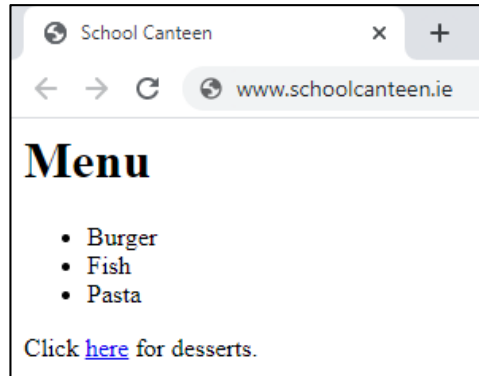

Complete the table below with the missing code.

Number	Missing Code
1	
2	
3	
4	



### Question 11

The intention of the JavaScript function below is to return a student grade descriptor based on a percentage grade as shown in the table to the right.

Percentage Grade	Descriptor
80 or over	Distinction
From 40 to 79	Pass
Less than 40	Unsuccessful

```
1 function getGradeDescription(percentageGrade) {
2     let gradeDescription = "Unsuccessful";
3
4     if (percentageGrade >= 80)
5         gradeDescription = "Distinction";
6
7     if (percentageGrade >= 40)
8         gradeDescription = "Pass";
9
10    return gradeDescription;
11
12 }
```

The code runs without any syntax errors but it does not always return the correct grade descriptor. Outline **one** way in which the function could be modified so that it works as intended.

**Question 12**

The travelling salesperson problem is commonly used in the study of algorithms and appears in formats similar to the problem below.

“Given a list of cities and the distances between each pair of cities, what is the shortest possible route that visits each city once and returns to the original city?”

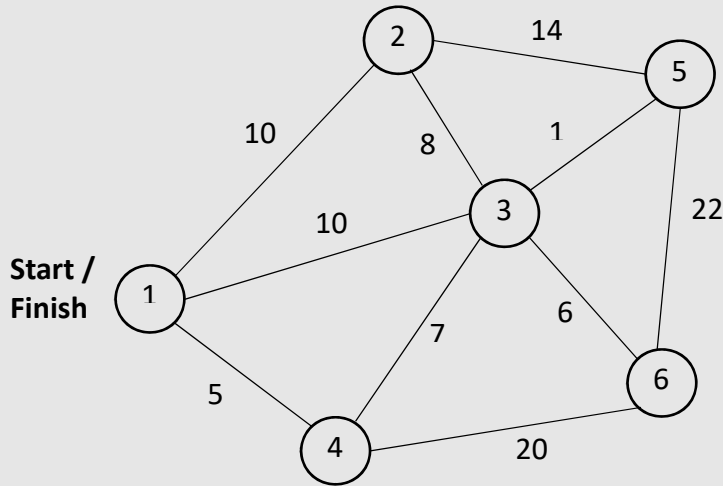

Why would *heuristics* be considered a good approach to solving a problem such as this?

Answer all three questions.

### Question 13

In his book *The Art of Computer Programming*, Donald Knuth states that “searching is the most time-consuming part of many programs, and the substitution of a good search method for a bad one often leads to a substantial increase in speed.”



- (a) The Python code below shows an implementation of a search algorithm. Examine the code and answer the questions that follow:

```
1 names = ["John", "Mary", "Zoe", "Alex", "Séamas"]
2 name = input("Enter lookup name: ")
3
4 found = False
5 index = 0
6
7 while (not found) and (index != len(names)):
8     if name == names[index]:
9         found = True
10    else:
11        index = index + 1
12
13 print("Result:", index)
```

- (i) State the name of the above search algorithm.

- (ii) What is the data type of the variable called **found**?

**(iii)** Step through how the algorithm finds the name *Zoe* in the list called **names**.

**(iv)** What would be the value of **index** after running the algorithm if the user entered a name that was not present in the list called **names**?

--

**(v)** What is the worst-case time complexity of this search algorithm? Explain your answer.

(b) Binary search is generally regarded as a highly efficient search algorithm.

(i) State **one** disadvantage of the binary search algorithm.

(ii) Step through how the binary search algorithm finds the integer 28 in the list **L** shown below.

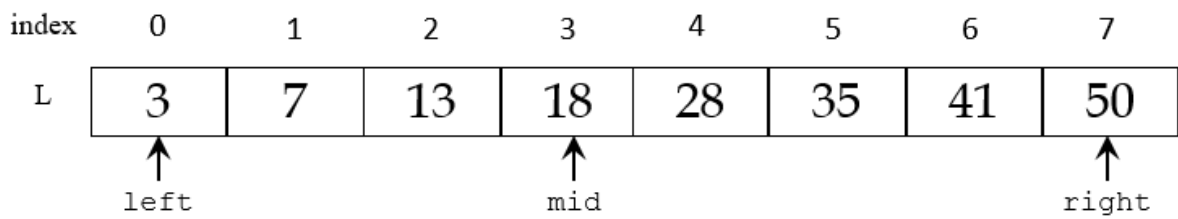

- (iii) What is the maximum number of comparisons the binary search algorithm would need to make if the value to be searched for did **not** exist in a list of 8 items?

Answer:

Space for rough work:



**Question 14**

Alan Turing is widely regarded as one of the founders of computer science because of his work on the development of the Turing Machine and the Turing Test.



(a) Explain the importance of Turing Machines as a computational tool.

(b) The illustration below depicts a Finite State Machine which, for a particular Turing Machine, defines two states, S1 and S2, and three transitions. Study the illustration and answer the questions that follow.



(i) What is the significance of state S2?

(ii) Complete the state transition table below based on the above Finite State Machine. The first row has already been completed.

Current State	Input	Output	Next State
S1	0	0	S1
S1			
S1			



- (iii) Starting from an initial state of S1 and an input of 10110B, as shown on the tape diagram below, show how the Turing Machine produces an output of 101100.

In your answer you should trace the computation clearly by showing the contents of the tape at the end of each state transition. You should complete the tape and the current state for each row. You can assume that the read/write head is moved one place to the right at the end of each step.

The first two rows have been completed for you.

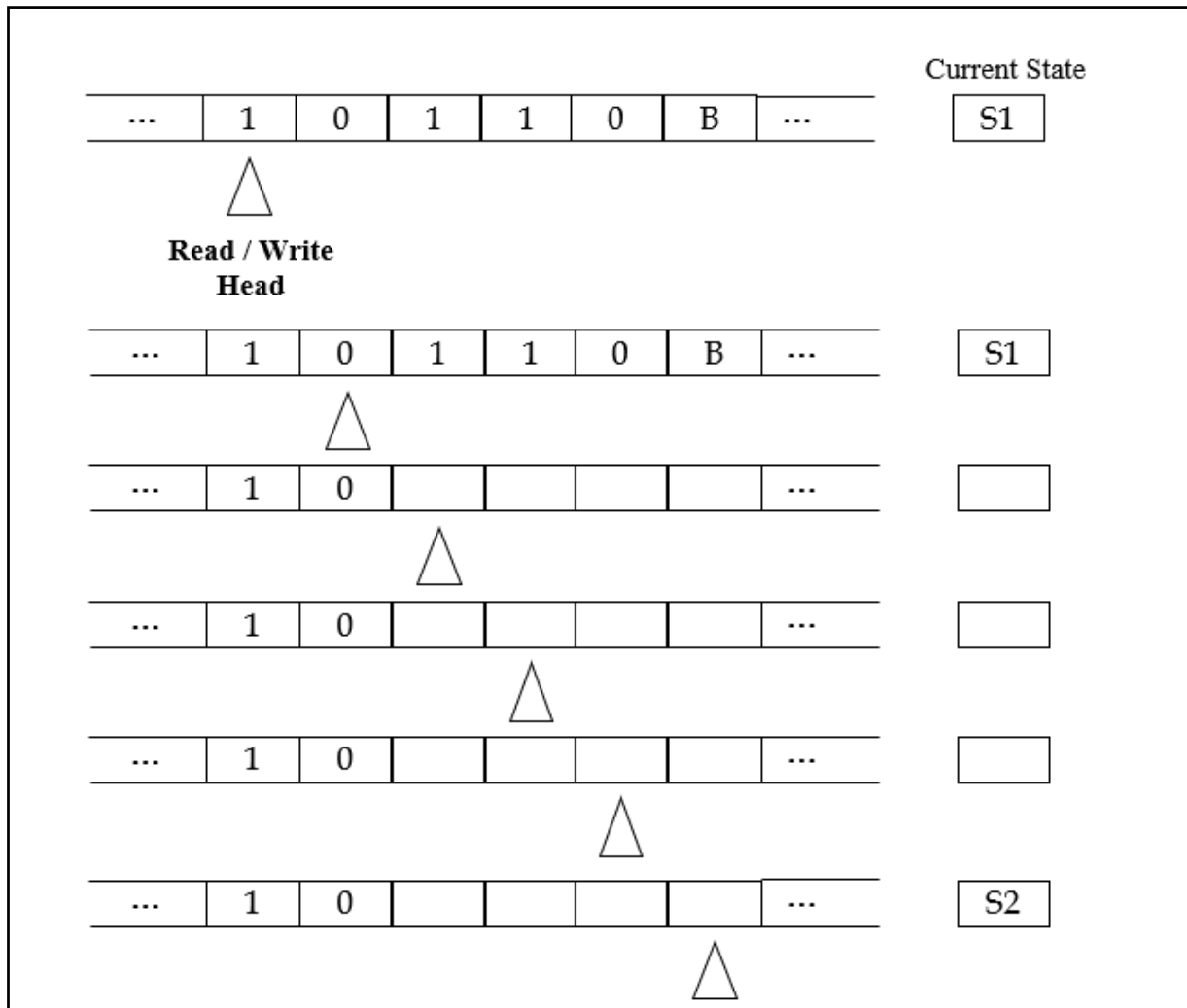





**Question 15**

*Rock Paper Scissors* is a popular two player game in which each player simultaneously picks one of three objects – rock, paper or scissors. The rules to determine the winner are relatively straightforward:

- Rock beats Scissors
- Paper beats Rock
- Scissors beats Paper

If both players choose the same object, the result is a draw (tie).



You have been asked to design and develop an interactive computerised *Rock Paper Scissors* game.

**(a)** State whether you would use a staged or iterative development process for the project. Justify your answer by giving **two** reasons for your decision.

Staged or Iterative:
Reason 1:
Reason 2:

- (b) As project manager one of your main tasks will be to form a project team and assign roles and responsibilities to the team members.

Identify **two** roles that would be appropriate for this project and for each role outline **two** responsibilities associated with that role.

Role 1:
Responsibility 1:
Responsibility 2:

Role 2:
Responsibility 1:
Responsibility 2:

(c) Your project team has identified two user interfaces that they observed in other *Rock Paper Scissors* games. Both of these interfaces are shown on the next page.

(i) Compare the two interfaces in terms of the types of applications and the functionality they offer.

## Rock Paper Scissors – User Interface 1

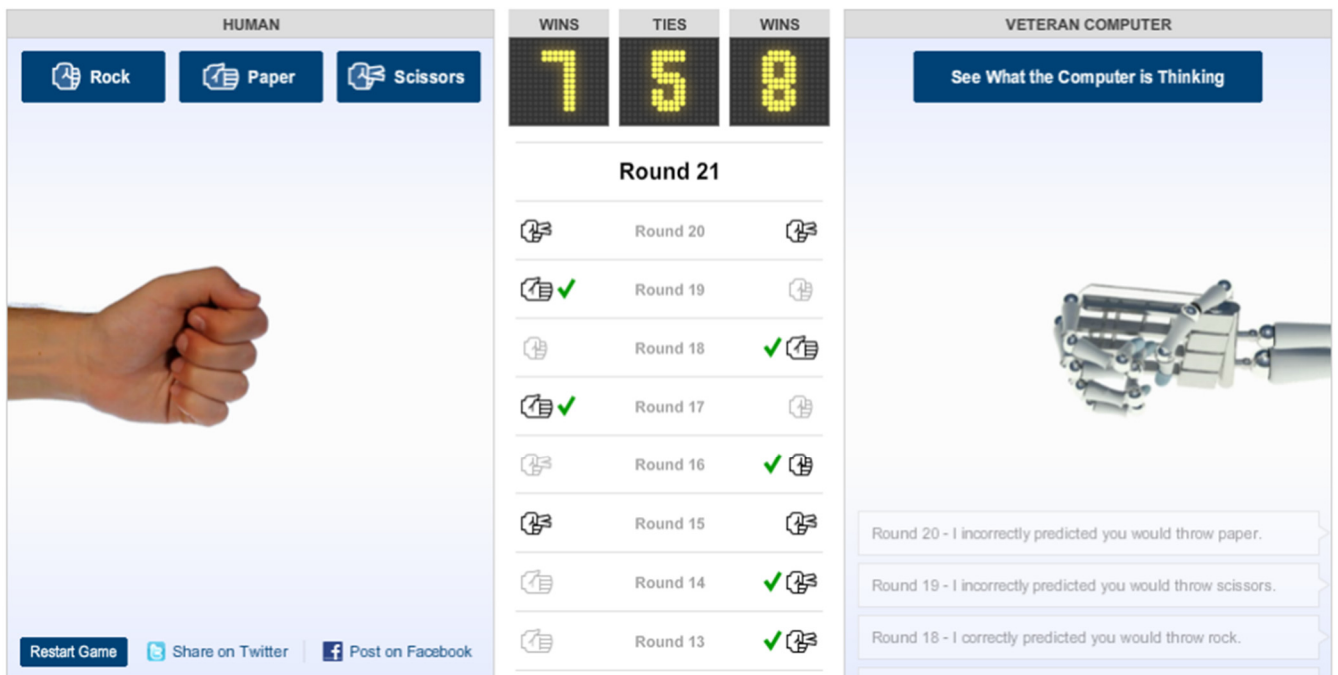

## Rock Paper Scissors – User Interface 2

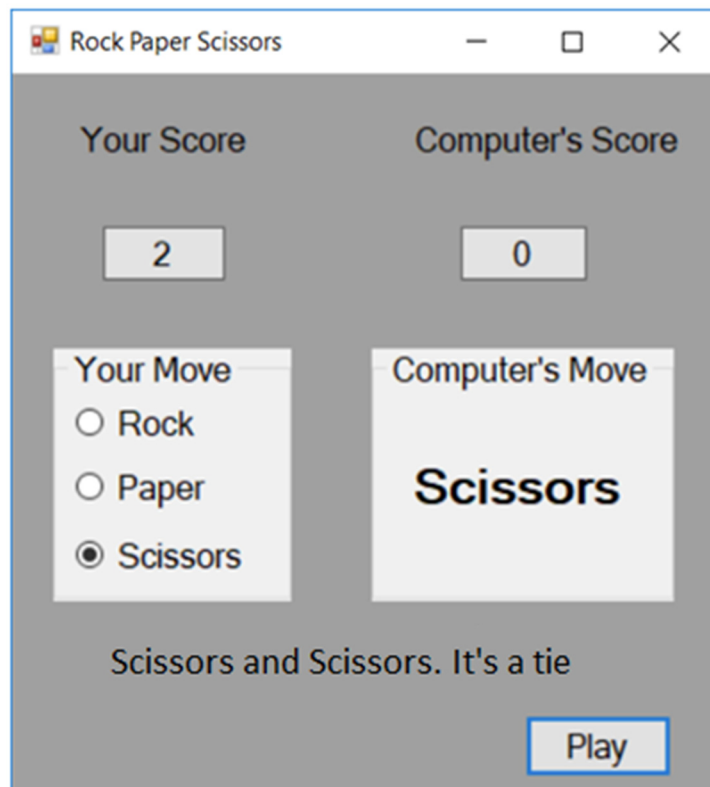

(ii) Provide **two** examples of how adaptive technology could be incorporated into a game of *Rock Paper Scissors*.

1.
2.







Space for extra work.

Indicate clearly the number and part of the question(s) you are answering.

## Acknowledgements

### Images

Image on page 11: [www.computerhistory.org/fellowawards/hall/donald-knuth/](http://www.computerhistory.org/fellowawards/hall/donald-knuth/)

Image on page 16: [www.britannica.com/biography/Alan-Turing](http://www.britannica.com/biography/Alan-Turing)

Image on page 20: [www.portablepress.com/blog/2017/11/how-to-win-at-rock-paper-scissors/](http://www.portablepress.com/blog/2017/11/how-to-win-at-rock-paper-scissors/)

Image 1 on page 23: [archive.nytimes.com/www.nytimes.com/interactive/science/rock-paper-scissors.html](http://archive.nytimes.com/www.nytimes.com/interactive/science/rock-paper-scissors.html)

Image 2 on page 23: [www.chegg.com/homework-help/questions-and-answers/rock-paper-scissors-game-application-write-c-program-allows-one-user-play-rock-paper-sciss-q32554392](http://www.chegg.com/homework-help/questions-and-answers/rock-paper-scissors-game-application-write-c-program-allows-one-user-play-rock-paper-sciss-q32554392)

### Texts

Quote on page 11: Donald E. Knuth, *The Art of Computer Programming* (Vol III Searching and Sorting, 2nd ed., Pgs. 392-393)

### Copyright notice

This examination paper may contain text or images for which the State Examinations Commission is not the copyright owner, and which may have been adapted, for the purpose of assessment, without the authors' prior consent. This examination paper has been prepared in accordance with Section 53(5) of the *Copyright and Related Rights Act, 2000*. Any subsequent use for a purpose other than the intended purpose is not authorised. The Commission does not accept liability for any infringement of third-party rights arising from unauthorised distribution or use of this examination paper.

Leaving Certificate – Higher Level

**Computer Science – Sections A & B**

1 hour 30 minutes